



SPFA-104

Spray Polyurethane Foam Systems for New and Remedial Roofing

Spray Polyurethane Foam Alliance

O: (800) 523-6154 | F: (703) 563-7425

www.sprayfoam.org | info@sprayfoam.org

Copyright 2008, 2015, 2023 Spray Polyurethane Foam Alliance (SPFA)
All rights reserved. No part of this publication may be altered, reproduced,
stored in a retrieval system, shared, distributed or transmitted, in any
form or by any means, electronic, mechanical, photocopying, recording or
otherwise, without the prior and express written permission of SPFA.

ABOUT SPRAY POLYURETHANE FOAM ALLIANCE (SPFA)

Founded in 1987, the Spray Polyurethane Foam Alliance (SPFA) is the voice, and educational and technical resource, for the spray polyurethane foam industry. A 501(c)6 trade association, the alliance is composed of contractors, manufacturers, and distributors of polyurethane foam, related equipment, and protective coatings; and who provide inspections, surface preparations, and other services. The organization supports the best practices and the growth of the industry through a number of core initiatives, which include educational programs and events, the SPFA Professional Installer Certification Program, technical literature and guidelines, legislative advocacy, research, and networking opportunities. For more information, please use the contact information and links provided in this document.

DISCLAIMER

This document was developed to aid building construction and design professionals in choosing spray-applied polyurethane foam systems. The information provided herein, based on current customs and practices of the trade, is offered in good faith and believed to be true to the best of SPFA’s knowledge and belief.

THIS DOCUMENT IS MADE AVAILABLE “AS IS” AND WITHOUT WARRANTIES OF ANY KIND, EITHER EXPRESS OR IMPLIED, INCLUDING THE WARRANTIES OF MERCHANTABILITY, FITNESS FOR A PARTICULAR PURPOSE, SATISFACTORY QUALITY, AND NON-INFRINGEMENT. TO THE FULLEST EXTENT PERMITTED BY APPLICABLE LAW, SPFA, ITS OFFICERS, DIRECTORS, EMPLOYEES, AUTHORIZED AGENTS AND VOLUNTEERS DISCLAIM ANY AND ALL LIABILITY OR RESPONSIBILITY FOR ANY LOSSES, DAMAGES, COSTS AND/OR INJURIES OF ANY KIND OR NATURE ARISING OUT OF OR RESULTING FROM THE USE AND/OR RELIANCE UPON THE CONTENTS OF THIS DOCUMENT.

Individual manufacturers and contractors should be consulted for specific information. Nominal values which may be provided herein are believed to be representative but are not to be used as specifications nor assumed to be identical to finished products. SPFA does not endorse the proprietary products or processes of any individual manufacturer, or the services of any individual contractor.

DOCUMENT HISTORY

Date	Sections Modified	Description of Changes
October 2008		
August 2015	All	Administrative changes
January 2023	All	Review and Update

ROOFING COMMITTEE

Mission Statement

The mission of the Roofing Committee is to provide a wide range of technical service to the SPF (spray polyurethane foam) industry such as, but not limited to:

- (1) Review existing documents and serve as a clearing house to ensure the “Continuity of Value” of technical information published by SPFA and others concerning roofing system products and services to the SPF industry;
- (2) Review, research, develop, and issue documents concerning new products, systems and services for SPF roofing applications; and
- (3) To identify, explore, develop, and communicate an understanding of roofing technical issues facing to the SPF industry.

Participating Members	
Bruce Schenke - Chair Carlisle Construction Materials	Roger Morrison, Deer Ridge Consulting
Eric Banks, e.w. banks consulting llc	Pat McCoy, BASF
Jeff Sowder, Chemours	Chris West, West Roofing Systems
Robb Smith, RGS Consulting	Bob LePage, EX-E1

TABLE OF CONTENTS

DISCLAIMER..... 2

DOCUMENT HISTORY 2

ROOFING COMMITTEE..... 3

Mission Statement 3

TABLE OF CONTENTS..... 4

DESIGN CONSIDERATIONS 7

 GENERAL CONSIDERATIONS 7

 SURFACE/DECK PREPARATION, PROCEDURES, AND CONSIDERATIONS 8

 SELECTION OF PRIMER..... 9

 SELECTION OF THE POLYURETHANE FOAM SYSTEM 9

 SELECTION OF PROTECTIVE COATING 9

 MAINTENANCE PROCEDURES..... 10

RECOMMENDED GUIDE SPECIFICATIONS FOR NEW AND REMEDIAL ROOFING..... 10

PART 1 – GENERAL 11

 1.01 SCOPE OF WORK 11

 1.02 RELATED WORK SPECIFIED ELSEWHERE 11

 1.03 QUALITY ASSURANCE..... 11

 1.04 SUBMITTALS..... 12

 1.05 MATERIALS, DELIVERY AND STORAGE 12

 1.06 ENVIRONMENTAL CONDITIONS..... 12

 1.07 SEQUENCING AND SCHEDULING 13

 1.08 WARRANTY..... 13

PART 2 — PRODUCTS..... 13

 2.01 POLYURETHANE FOAM 13

 2.02 PROTECTIVE COATING 14

 2.03 ACCESSORIES AND MISCELLANEOUS MATERIALS 15

PART 3 – EXECUTION 15

 3.01 GENERAL 15

 3.02 SURFACE PREPARATION AND PRIMING..... 16

3.03 POLYURETHANE FOAM APPLICATION (SPF) 18

3.04 PROTECTIVE COATING APPLICATION..... 19

3.05 GRANULE APPLICATION (Optional)..... 20

3.06 WALKWAYS 20

3.07 SAFETY REQUIREMENTS..... 20

APPENDIX A: Detail Drawings 21

 Detail Drawing 1: New & Remedial Roof Edge 22

 Detail Drawing 2: Remedial Tie-in To Existing Metal Edge 23

 23

 Detail Drawing 3: Typical Roof Edge with Gutter 24

 Detail Drawing 4: New Metal Parapet Cap 25

 Detail Drawing 5: Existing Parapet with Coping 26

 Detail Drawing 6: New Flashing for Wall Supported Deck 27

 Detail Drawing 7: High Wall Remedial Through Wall Flashing 28

 Detail Drawing 8: Flashing for New Non-wall Supported Deck 29

 Detail Drawing 9: New or Remedial Siding or High Wall 30

 Detail Drawing 10: Typical Existing Area Divider 31

 Detail Drawing 11: Remedial Area Divider 32

 Detail Drawing 12: Typical Roof Drain 33

 Detail Drawing 13: New or Remedial Roof Drain 34

 Detail Drawing 14: Remedial Drain Insert 35

 Detail Drawing 15: New Expansion Joint 36

 Detail Drawing 16: Remedial Expansion Joint 37

 Detail Drawing 17: Skylight, hatch or smoke vent curb..... 38

 Detail Drawing 18: New or remedial hot stack flashing 39

 Detail Drawing 19: Flat Roof to shingle Tie in..... 40

 Detail Drawing 20: New and Remedial Fluted Metal Deck..... 41

 Detail Drawing 21: Water Stop 42

 Detail Drawing 22: Remedial Protrusion Flashing 43

 Detail Drawing 23: Raised Curb Detail (Prefabricated Metal Curb) 44

 Detail Drawing 24: Raised Curb Detail (Job Site Construction Wood Curb)..... 45

Detail Drawing 25: Remedial Air Conditioner Treatment..... 46

APPENDIX B: Surface Texture of Spray Polyurethane Foam 47

 SURFACE TEXTURE OR FINISH..... 47

 Smooth Surface Texture (1) 48

 Orange Peel Surface Texture (2)..... 49

 Coarse Orange Peel Surface Texture (3)..... 50

 Verge of Popcorn Texture (4)..... 51

 Popcorn Surface Texture (5) 52

 Treebark Surface Texture (6) 53

OTHER PROGRAMS AND SERVICES OFFERED BY SPFA 54

 Professional Training..... 54

 Technical Documents..... 54

DESIGN CONSIDERATIONS

GENERAL CONSIDERATIONS

The performance of a spray-applied polyurethane foam (SPF) roofing system can be affected by all the component parts of a roof structure, as well as the ambient conditions inside and outside the structure.

Proper structural design, specification review, and contractor and material selection, coupled with the compatibility and positioning of the various components of a roof structure, are all necessary to produce a successful roofing system.

The roof design and construction must comply with all applicable codes and ordinances and be approved by the Authority or Authorities Having Jurisdiction (AHJ).

Consult with the respective material suppliers and the successful contractor to receive written confirmation of their agreement to all facets of the roofing system, including, but not limited to, material selection, drainage, expansion joints, load design, flashing details, deck preparation, etc.

TERMINOLOGY and DEFINITIONS

Additional definitions and terms can be referenced in SPFA-119 “Glossary of Terms”. The most relative to this document at the time of last review are provided below.

Combustible: Capable of burning –*a combustible roof deck is usually made of wood.*

Non-Combustible: Generally not capable of burning – a non-combustible roof deck is made of steel or concrete or material that do not burn.

Recovering: The process of installing a new roofing system over an existing roofing system.

Replacement: The process of removing an existing roof and installing a new roofing system.

Re-Roofing: Either the recovering or the replacement of a roofing system.

Roof Assembly: An assembly of interacting roof components including the roof deck, air or vapor retarder (if present), insulation, flashings, and membrane or primary roof covering designed to weatherproof a structure.

Roof Deck: The structural surface to which a roofing or waterproofing system is applied. Spray polyurethane foam may be applied to decks on the exterior side as an insulated roofing system.

SURFACE/DECK PREPARATION, PROCEDURES, AND CONSIDERATIONS

SPF can be successfully applied to most surfaces. However, the following general practices must be observed on all decks that are receiving SPF. See SPFA-138, “Guideline for Roof Assembly Evaluation for Spray Polyurethane Foam Roof System.”

(1) General Surface/Deck Preparation Procedures

- a. Lightning rod protective system components shall not be embedded in the polyurethane foam and must be removed or abandoned prior to installation of SPF. Electrical and mechanical conduits should be relocated or raised above the finished roof surface. Lightning protection equipment and electrical work must be performed by qualified personnel.
- b. The roof deck shall be securely fastened to the building structure and conform to proper load limits defined by the applicable building code. Special attention should be focused on the deflection under all types of conditions, including, but not limited to, foot traffic, mechanical equipment utilization, and live and dead loads.
- c. When either or both a primer and a vapor retarder are specified, there must be adequate adhesion between all components of the system to secure the entire system against wind uplift and movement.
- d. Prior to application of primer, vapor retarder, or polyurethane foam, the deck shall be properly cured, dry, and free of loose dirt or any contaminants that may interfere with proper adhesion of any of these respective components.
- e. Deck contaminants, depending on their severity and quantity, may be removed by use of air pressure, vacuum equipment, hand or power broom, chemical solvents, sandblasting, manual scraping, pressure washing, etc.

(2) Wood Surfaces/Decks

- a. Pre-treatment with a primer is often recommended to achieve maximum adhesion of the polyurethane foam to a wood deck.
- b. Joints in excess of 1/4 in. in width shall be sealed prior to the application of primer, vapor retarder, or polyurethane foam.

(3) Metal Surfaces/Decks

- a. A pitch of 1/4 in. in 12 in. or more is recommended for the finished roof system
- b. A structural metal deck should not be thinner than 22 gauge.
- c. Sloped metal roof panels should not be thinner than 29 gauge.
- d. All joints should be correctly, sealed, and fastened.
- e. Underlayment, if specified for the smoother application of polyurethane foam should be of sufficient width and thickness to span or fill flutes. Fastening shall be in accordance with applicable code requirements.

(4) Concrete Surfaces/Decks

- a. In all cases, concrete should be free of laitance and chemical release agents.
- b. Priming may be required on concrete surfaces. It is recommended that, due to the water of hydration that is present, poured concrete decks be permitted to cure for 28 days at 75°F or have a surface moisture content below 18% prior to the application of sprayed polyurethane foam.
- c. All joints should be filled and/or taped.
- d. SPF is not recommended for lightweight or insulating concretes unless an overlayment is installed.

SELECTION OF PRIMER

Consult the SPF manufacturer for the manufacturer's recommendations for proper primer selection according to the surface to be sprayed.

SELECTION OF THE POLYURETHANE FOAM SYSTEM

~~SPF systems used as above deck roofing insulation are specially formulated to provide the required performance and accommodate a wide range of ambient conditions at the time of installation.~~

As a purchaser, you should understand that most published data is obtained using laboratory produced samples tested under laboratory conditions. The thickness of polyurethane foam sprayed, number of passes, temperatures of substrate, ambient temperatures, solar exposure and shading, etc., influence the final spray foam product.

From a fire safety standpoint, polyurethane foams can be used safely. It is important, however, that all persons associated with the design, fabrication, storage, and installation of polyurethane foam products understand the materials and follow the manufacturer's material safety guidance.

SELECTION OF PROTECTIVE COATING

When spray-applied polyurethane foam is applied externally, as an integral part of the roofing system, and subject to degradation with long-term exposure to sunlight and weather; therefore, a protective covering for weather protection is necessary.

Typically, the required protection is attained through application of an elastomeric liquid-applied coating system, following the manufacturer's recommendations.

The properties of the cured protective coating shall meet the minimum design characteristics of

performance requirements for the generic type specified (ASTM D6083, D6694 or D6947). The protective coating shall be specifically manufactured for the weather protection of polyurethane foam as used in roofing applications.

The protective coating shall be a system that cures to form a weather-resistant protective membrane resistant to water and ultraviolet (UV) degradation. The dry-film thickness (DFT) of the protective coating shall comply with the coating manufacturer's specification and any applicable third-party certified design.

Following are design considerations for selection of SPF coating materials.

(1) Physical Characteristics

- a. Chemical resistance
- b. Water vapor permeance
- c. Tensile and elongation properties
- d. Retention of physical properties with aging
- e. UV resistance

(2) Performance Considerations

- a. Environment and intended use (foot traffic, hail resistance, etc.)
- b. Life expectancy
- c. Maintenance
- d. History of similar applications or laboratory data relating to the application in question
- e. Adhesion to the polyurethane foam
- f. Combustibility characteristics, individually and in combination with the selected polyurethane foam systems
- g. Ability to withstand foot traffic
- h. Aesthetic qualities

MAINTENANCE PROCEDURES

It is strongly recommended that maintenance procedures, including annual inspections, be established with your selected contractor and the building owner for any roofing system to yield maximum longevity of the roof system.

Contact the respective manufacturers/suppliers and contractors for their recommended maintenance procedures.

RECOMMENDED GUIDE SPECIFICATIONS FOR NEW AND REMEDIAL ROOFING

NOTE: This guide is designed to help the specifier achieve a successful polyurethane foam and coating roofing system. It is the responsibility of the specifier to consult with the manufacturer of the material specified as to the manufacturer's specific recommendations.

PART 1 – GENERAL

This guide discusses the application of a seamless, sprayed-in-place polyurethane foam with a protective coating for use as an insulated roofing system for new or retrofit roofing. Your contractor, the selected system’s manufacturer(s), and the AHJ(s) can assist you, as each project must be assessed individually.

1.01 SCOPE OF WORK

Furnish all labor, materials, tools, and equipment necessary for the application of a polyurethane foam roofing system, including accessory items, subject to the general provisions of the contract.

1.02 RELATED WORK SPECIFIED ELSEWHERE

Cast-in-place Concrete	Section 03300
Metal Decking	Section 05300
Rough Carpentry	Section 06100
Insulation	Section 07200
Membrane Roofing	Section 07500
Flashing and Sheet Metal	Section 07600
Roof Specialties and Accessories	Section 07700
Skylights	Section 07800
Mechanical	Division 15
Electrical	Division 16

1.03 QUALITY ASSURANCE

- (1) Contractor Qualifications: The proposed contractor should provide information concerning projects similar in nature to the one proposed, including location and person to be contacted. Some manufacturers of SPF systems and/or protective coatings have approval programs and/or accreditation methods that could be required.
- (2) Manufacturer Qualifications: Polyurethane foam and protective coating manufacturers shall show evidence of sufficient financial resources and manufacturing facilities to furnish the materials for this project. References shall be required, and sufficient project lists, warranties, and code approvals shall be submitted for verification.
- (3) Inspections: The polyurethane foam and protective coating manufacturers may provide qualified representatives to monitor and inspect the installation of their products. Third-party inspection of the completed installation is recommended. A list of SPFA inspector members is available.
Note that initial and ongoing inspections are typically required when the roof system is subject to warranty coverage.
- (4) Daily Logs: Contractor should maintain daily logs during application of spray polyurethane

foam.

1.04 SUBMITTALS

- (1) Manufacturers are to provide published data sheets or evidence of third-party certification confirming that their products comply with the materials specified. This is to include primers (if required), polyurethane foam, and protective coatings.
- (2) Shop drawings of sheet metal, accessories, or other fabricated items.
- (3) Manufacturers' application or installation instructions.
- (4) Contractor/applicator certification from the polyurethane foam supplier and/or protective coatings manufacturers and evidence of contractor/applicator qualification and experience. (See Section 1.03(1))
- (5) A specimen copy of the applicable warranty for the project.
- (6) Approval and information guides for applicable codes, ordinances and/or insurance acceptability, as required.
- (7) Safety and handling instructions for storage, and the handling and use of the materials to include appropriate Safety Data Sheets (SDS).
- (8) Field Quality Control Procedures to be utilized by the contractor/applicator to ensure proper preparation and installation of polyurethane foam and protective coatings, detail work, and follow-up inspection.
- (9)

1.05 MATERIALS, DELIVERY AND STORAGE

- (1) Materials shall be delivered in the manufacturers original, tightly sealed containers, or unopened packages, all clearly labeled with the manufacturer's name, product identification, safety information, batch or lot numbers, and date of manufacture where appropriate.
- (2) Containers shall be stored out of the weather and direct solar exposure where the temperatures are within the limits specified by the manufacturer.
- (3) All materials shall be stored in compliance with local fire and safety requirements.

1.06 ENVIRONMENTAL CONDITIONS

- (1) The polyurethane foam applications shall not proceed during periods of inclement weather. Do not apply the polyurethane foam below the temperature and/or above the humidity for ambient air and substrate specified by the manufacturer.
- (2) Do not apply protective coatings when there is ice, frost, surface moisture, or other visible dampness is present on the surface to be coated. Prior to applying the coatings, check the polyurethane foam to ensure the surface is dry. Apply protective coatings in accordance with the coating manufacturer's application instructions.
- (3) Wind barriers may be used if wind conditions could affect the quality of the polyurethane foam or protective coating installation.

1.07 SEQUENCING AND SCHEDULING

In new construction projects, the SPF is installed when the deck, parapet walls, rough openings, and curbs are completed. Plumbing vents, drains, and electrical penetrations should all be in place prior to installation of SPF roof systems. If penetrations are to be added after the SPF is installed, proper preparation and use of compatible materials are required. There should be no other tradespeople working on the roof when the SPF and coating are being installed.

1.08 WARRANTY

Warranty agreements vary in duration and terms. If a warranty is desired, establish parameters as a prerequisite to the execution of a contract.

PART 2 — PRODUCTS

2.01 POLYURETHANE FOAM

- (1) The polyurethane foam to be applied shall be a two-component system made by combining an isocyanate A-component with a polyol B-component and shall possess the physical characteristics for SPF material specification ASTM C1029 or D7425 and shall comply with applicable codes and ordinances.

Table 1: Properties for SPF per ASTM C1029 and ASTM D7425

PROPERTIES	ASTM Test Method	ASTM SPF Material Standard Specification		
		ASTM C1029 Type III	ASTM C1029 Type IV	ASTM D7425
Density	D1622	N/A	N/A	As reported
Compressive Strength	D1621	Min 40 psi (270 kPa)	Min 40 psi (270 kPa)	Min 40 psi (270 kPa)
Open Cell Content	D2856	Max 10% (max)	Max 10% (max)	Max 10% (max)
Dimensional Stability	D2126	Max 6% in any direction	Max 5% in any direction	Max 6% in any direction
R-Value*	C177, C518, C1363	Min 6.2 (1.09)	Min 6.2 (1.09)	As reported
Flame Spread	E84**	As reported	As reported	75 Flame Spread Index or Less

*Thermal resistance of 1.0 in. (25 mm) thickness, min, °F-ft²-h/Btu (K·m²/W) at mean temperature 75°F (24°C)

**This standard is used solely to measure and describe the properties of products in response to heat and flame under controlled laboratory conditions This numerical flame spread rating is not intended to reflect hazards presented by this or any other material under actual fire conditions.

- (2) Polyurethane Foam Primers: Primers used shall be as recommended by the manufacturer of the spray foam materials specified (see SPFA-143 Primers for Spray Polyurethane Foam Insulation and Roofing Systems).
- (3) Fire Safety Requirements: See American Chemistry Council Center for the Polyurethanes Industry “Fire Safety Guidelines for Use of Rigid Polyurethane and Polyisocyanurate Foam

Insulation in Building Construction.”

2.02 PROTECTIVE COATING

- (1) The elastomeric coating system may be one or more of the following types:
 - a. Acrylics (See ASTM D6083, “Standard Specification for Liquid Applied Acrylic Coating Used in Roofing.”)
 - b. Silicones (See ASTM D6694, “Standard Specification for Liquid-Applied Silicone Coating Used in Spray Polyurethane Foam Roofing.”)
 - c. Polyurethanes (See ASTM D6947, “Standard Specification for Liquid Applied Moisture Cured Polyurethane Coating Used in Spray Polyurethane Foam Roofing System.”)
- (2) For additional information on SPF roof coatings, see SPFA-102 A Guide for Selection of Elastomeric Protective Coatings Over Exterior Spray Foam Applications available from www.sprayfoam.org

Physical Property	ASTM Test Method	ASTM Coating Material Standard Specification			
		D6083 Type I - Acrylic	D6083 Type II- Acrylic	D6694 Silicone	D6947 Moisture-cure Urethane
Viscosity	D2126	12,000-85,000 cps	200-100,000 cps	3,500-50,000 cps	90-110 KU
% Solids by Volume	D2697	>50%	>45%	>57%	>65%
% Solids by Weight	D1644	>60%	>50%	as listed by manufacturer	as listed by manufacturer
Initial Elongation (break)@23°C (73°F)	D2370	Min 100%	Min 100%	Min 100%	Min 350%
Initial Tensile Strength @23°C (73°F)	D2370	Min 200 psi (1.4 MPa)	Min 200 psi (1.4 MPa)	Min 150 psi (1.03 MPa)	Min 600 psi (4.14 MPa)
Final Elongation (break) after 1000 hours weathering @23°C (73°F)	D2370	Min 100%	Min 100%	Min 100% (@5000 hours)	Min 350%
Permeance	D1653	Max 50 Perms (2860 ng/s•m ² •Pa)	Max 50 Perms (2860 ng/s•m ² •Pa)	2.5 Perms (143 ng/s•m ² •Pa)	1 Perm (57 ng/s•m ² •Pa)
Water Absorption (mass)	D471	Max 20%	Max 20%	N/A	Max 3%
Accelerated Weathering	D4798/D4798M	no cracking or checking	no cracking or checking	no cracking or checking	no cracking or checking
Adhesion to substrate	D903	Min 2.0 lbf/in (350 N/m)	Min 2.0 lbf/in (350 N/m)	Min 2.0 lbf/in (350 N/m)	Min 2.0 lb/in (350 N/m)

Fungi Resistance	G21	zero rating	zero rating	N/A	zero rating
Tear Resistance	D624	> 60 lbf/in (21 kN·m)	> 60 lbf/in (21 kN·m)	>20 lbf/in (3.5 kN·m)	>100 lbf/in (17.5 kN·m)
Low-Temperature Flexibility after Weathering	D522/D522M	Min pass 0.5 in. (13 mm) mandrel -15°F (-26°C)	Min pass 0.5 in. (13 mm) mandrel 14°F (-10°C)	Min pass 0.5 in (1.27 cm) mandrel -15°F (-26°C)	Min pass 0.5 in (1.27 cm) mandrel -15°F (-26°C)

NOTE: The specifier shall list the physical properties of the chosen elastomeric coating system.

- (3) General: It is recommended that the coating system be elastomeric in nature (at least 100% elongation). Elastomeric coating systems include both vapor retarder and non-vapor retarder systems.

NOTE: Special consideration should be given to those applications, such as freezers and coolers, which roof assemblies on cold storage buildings because the service conditions for these type of roof assemblies may exceed conventional moisture vapor drive conditions.

2.03 ACCESSORIES AND MISCELLANEOUS MATERIALS

- (1) Flashings and waterproof coverings for expansion joints shall be compatible with the specified polyurethane foam and elastomeric coating system and shall be as recommended by the manufacturers of the systems specified.
- (2) Miscellaneous materials such as adhesives, elastomeric caulking compounds, metal, vents, and drains shall be a composite part of the roof system and shall be those recommended by the system’s manufacturer.
- (3) Granules (optional): When used, granules shall be of the size and type and applied in the topcoat as recommended by the coating manufacturer.
- (4) Board stock: If rigid foam is specified for use as a cover board over metal decks, fasten to achieve the necessary wind uplift requirements.

PART 3 – EXECUTION

3.01 GENERAL

Installation shall comply with the warranty program requirements, where applicable.

3.02 SURFACE PREPARATION AND PRIMING

(1) Re-covering of Bituminous Built-up Roof and Modified Bitumen

- a. All loose gravel, dust, and contaminants shall be removed using roof vacuum, a power sweeper, air blowing, or other suitable means.
- b. The roof shall be thoroughly inspected or tested to determine if moisture is present within the roof assembly. Wet insulation must be removed and replaced with compatible materials.
- c. The existing roof shall be thoroughly inspected for adhesion between felts, insulation, and deck. Areas of poor adhesion shall be fastened. Blisters, buckles, wrinkles, and fishmouths shall be cut out and/or fastened.
- d. All soft mastic or other materials that impede polyurethane foam adhesion shall be removed or covered with a mechanically fastened re-cover board.
- e. Remove and replace, or refasten, all loose base flashing, counterflashing, coping and perimeter edge metal as required.
- f. Structural design analysis may be necessary to determine expansion joint requirements. Existing expansion joints shall be inspected and repaired if necessary.

(2) Metal Deck

- a. The metal roof deck shall be constructed of a minimum 22-gauge steel. Construction shall conform to local building codes.
- b. Ferrous Metal: Sandblast iron and steel surfaces that are not primed, shop-painted, or otherwise protected in accordance with Association for Materials Protection and Performance (AMPP) SSPC-SP6/NACE No. 3-2006 "Commercial Blast Cleaning." Remove loose rust and unsound primer from shop-primed iron and steel surfaces by scraping or wire brushing.
- c. Non-ferrous Metal: Clean and/or prime galvanized metal, aluminum, and stainless steel surfaces as recommended by the manufacturer issuing the warranty.
- d. If the metal surface is free of loose scale, rust, and weathered or chalking paint, it can be cleaned using a compressed air jet, vacuum equipment, and a hand or power broom to remove loose dirt. Grease, oil, or other contaminants shall be removed with proper cleaning solutions.
- e. Fluted metal decks require a suitable method of covering or filling the flutes prior to polyurethane foam application otherwise the profile of the SPF will be similar to the metal deck. Flutes may be covered with mechanically fastened board stock or open weave mesh fabric or filled with precut board stock or spray-applied polyurethane foam.

(3) Concrete

- a. Remove loose dirt, dust, laitance, and debris by using a compressed air jet, vacuum equipment, or brooming. Oil, grease, form release agents, or other contaminants shall be removed with proper cleaning solutions.
- b. All joint openings in concrete decks that exceed 1/4 in. shall be grouted or caulked prior to application of polyurethane foam.

- c. Priming may be required on concrete surfaces, and it is recommended that poured concrete decks be permitted to cure for a minimum of 28 days or the concrete surface has a moisture content less than 18% prior to the application of primer or SPF.
- d. SPF is not recommended for lightweight or insulating concretes unless an overlayment is installed.

(4) Wood

- a. Plywood/OSB decking shall be exterior grade but not pressure treated, not less than nominal 1/2 in. thick and attached firmly in place. A thermal barrier covering may need to be installed below the foam if wood decking is not qualified as a thermal barrier. Decking and attachment must meet building code requirements for resistance to wind uplift.
- b. Plywood/OSB shall contain no more than 18% water, as measured in accordance with ASTM D4442 and D4444.
- c. All untreated and unpainted surfaces shall be primed with an exterior grade primer. See manufacturers recommendations for treated lumber preparation. Priming is required to minimize moisture absorption and eliminate potential polyurethane foam adhesion problems.
- d. Deck joints in excess of 1/4 in. shall be taped or filled with a suitable sealant material.
- e. The deck shall be free of loose dirt, grease, oil, or other contaminants prior to priming or SPF application. Remove loose dirt or debris using a compressed air jet, vacuum equipment, or brooming. No washing shall be permitted.
- f. Tongue and Groove, Sheathing, and Planking: Due to the frequency of joints, possibility of variable openings, and effects of aging and shrinking, these surfaces must be overlaid with a minimum 1/4 in. thick properly secured, exterior grade plywood or suitable covering.

(5) Other Surfaces (e.g., roof cover boards)

- a. These materials are generally used over existing roof decks and roof systems decks and must be securely fastened to achieve necessary wind uplift requirements.
- b. Boards shall be firmly butted together along all the edges without gaps or openings. Joints exceeding 1/4 in. shall be caulked with a suitable sealant material.
- c. Special care must be taken to prevent these materials from getting wet in storage on the jobsite and prior to being protected by polyurethane foam after installation. Moisture exposure will damage these materials and may be a cause for replacement.
- d. Remove loose dirt and debris by using a compressed air jet, vacuum equipment, or light brooming. Note that shovels, power-brooms and other equipment may damage the surface of roof cover boards.
- e. Roof cover boards that are contaminated with materials that affect the adhesion of SPF must be removed and replaced.

3.03 POLYURETHANE FOAM APPLICATION (SPF)

(1) Inspection

- a. Prior to application of the SPF, the surface shall be inspected to ensure that the conditions required by Section 3.02 have been met.
- b. The substrate shall have sufficient slope to eliminate excessive ponding water. Ponding is defined in SPFA-119 Glossary of Terms as *"the accumulation of water in low-lying areas that exceeds the manufacturer's specification or contract documents."* If the substrate does not have sufficient slope, the potential for ponding water must be eliminated by developing slope through the SPF application, by the proper placement of drains, or a combination thereof.
- c. The polyurethane foam application shall not proceed during periods of inclement weather. The applicator shall not apply the polyurethane foam below the temperature and/or humidity for ambient air and substrate specified by the manufacturer. Wind barriers may be used if wind conditions could affect the quality of installation.

(2) Application

- a. The SPF shall be applied in accordance with the manufacturer's specification and instructions.
- b. Areas to be built-up to remove ponding water are to be filled in with SPF before the specified thickness of the polyurethane foam is applied to the entire roof surface.
- c. The lift thicknesses of the SPF must be applied in a minimal thickness of 1/2 in. and a maximum thickness of 1-1/2 in. per lift. or per manufacturer's recommendations.
- d. Total SPF thickness shall be a minimum of 1 in. (or more if specified), except where variations are required to ensure proper drainage or to complete a feathered edge.
- e. The SPF shall be uniformly terminated a minimum of 4 in. above the final installed thickness of the SPF at all penetrations (except drains, parapet walls, or building junctions). SPF cants shall be smooth and uniform to allow positive drainage.
- f. When detailing skylights or terminations on walls that have weep (drainage) holes, it is particularly important not to cover weep holes with SPF or coating.**
- g. The full thickness of SPF in any area shall be completed prior to the end of each day. If, due to weather conditions, more than 24 hours elapse between SPF and coating application, the SPF shall be inspected for UV degradation, oxidation, or contamination. If any of the foregoing conditions exist, the surface shall be prepared in conformity with the recommendations of the manufacturer issuing the warranty.

(3) Surface Finish

- a. The final SPF surface shall be smooth, orange peel, coarse orange peel, or verge of popcorn in texture. SPF surfaces termed "popcorn" or "tree bark" are not

- acceptable. These areas shall be removed, and new SPF applied to an acceptable surface. (See surface texture photos in Appendix B.)
- b. Any damage or defects to the SPF surface shall be repaired prior to the protective coating application.

3.04 PROTECTIVE COATING APPLICATION

(1) Inspection

- a. Prior to the application of the protective coating, the polyurethane foam shall be inspected for suitability of base coat application as per Section 3.03. The SPF surface shall be free of moisture, frost, dust, debris, oils, tars, grease, or other materials that will impair the adhesion of the protective coating.

(2) Application

- a. Base Coat or Initial Coat
 - i. The coating application shall not proceed during periods of inclement weather. The applicator shall not apply the protective coating below the temperature and/or above the humidity for ambient air and substrate specified by the manufacturer. Wind barriers may be used if wind conditions could affect the quality of installation.
 - ii. The base coat shall be applied on the same day as the SPF application when possible. Allow SPF to cure for two hours before application of the base coat. If more than 24 hours elapse prior to the application of base coat, the SPF shall be inspected for UV degradation.
 - iii. The SPF shall be free of dust, dirt, contaminants, and moisture before the application of the base coat.
 - iv. The base coat shall be applied at a uniform thickness with the rate of application being governed by the SPF surface texture. Coatings shall be applied at such a rate as to give the minimum dry-film thickness specified by the protective coating manufacturer or specifier.
 - v. The coating shall be allowed to cure and shall be inspected for pinholes, thinly coated areas, uncured areas, or other defects. Any defects shall be repaired prior to subsequent applications. The base coat shall be free of dirt, dust, water, or other contaminants before the application of the topcoat.
- b. Topcoat or Subsequent Coat(s)
 - i. Application – Subsequent coating should be applied in a timely manner to ensure proper adhesion between coats. The surface texture of the polyurethane foam will affect the dry-film thickness—additional material may

be required in areas with a coarse SPF profile.

- ii. Inspection – The cured dry-film thickness of the finished multiple-coat application shall be checked by taking slit samples and examining the samples under magnification. Areas that are found to have less than the thickness specified shall require additional coating.

3.05 GRANULE APPLICATION (OPTIONAL)

Granules should be applied at a rate and using a method based on the manufacturer's recommendations. Granules, when specified, should be embedded in the topcoat. Apply the granules into the final layer of the coating while it is still wet.. The color and type of granules shall be approved by the specifier.

3.06 WALKWAYS

Walkways may be installed for heavy traffic areas and around frequently serviced rooftop units. Breathable walk pads should be installed as recommended by the coating manufacturer. Alternately, walkways may be made using additional layer of coatings and granules in a contrasting color.

3.07 SAFETY REQUIREMENTS

- (1) See American Chemistry Council CPI document AX-205, "Guidance for Working with MDI: Things You Should Know."
- (2) Refer to appropriate Safety Data Sheets (SDS) for additional safety information regarding chemical safety.
- (3) Before starting to apply SPF or coating, any potential sources of air entry into the building must be sealed.
- (4) Implement a fall protection program as well as all applicable jobsite safety requirements by Federal or State OSHA programs.

APPENDIX A: Detail Drawings

All detail drawings developed in AutoCAD for SPFA, courtesy of West Roofing Systems, Inc., Lagrange, OH. Each detail may be downloaded as separate AutoCAD dxf file from this location:

[SPFA-104 AutoCAD Detail Files | Powered by Box](#) or

<https://app.box.com/folder/191241449110?s=colbk7x97guajsj2lgzmf4kv4zk8t7jg>

DETAIL DRAWING 1: NEW & REMEDIAL ROOF EDGE

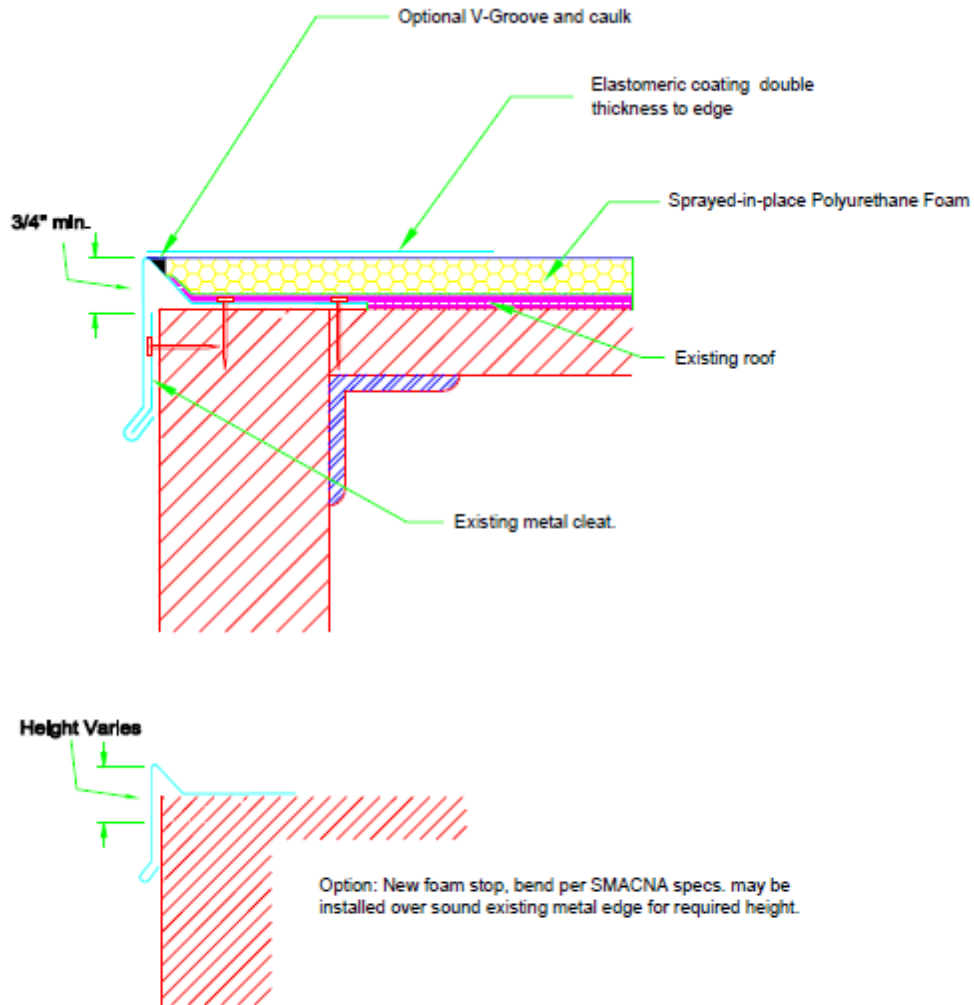

NOTES:

Properly prepare existing metal edge flashing.
 On existing BUR with gravel embedment, spud clean the metal edge to expose approximately 3/4" of the metal edge. Prime exposed metal and secure as needed.

DETAIL DRAWING 2: REMEDIAL TIE-IN TO EXISTING METAL EDGE

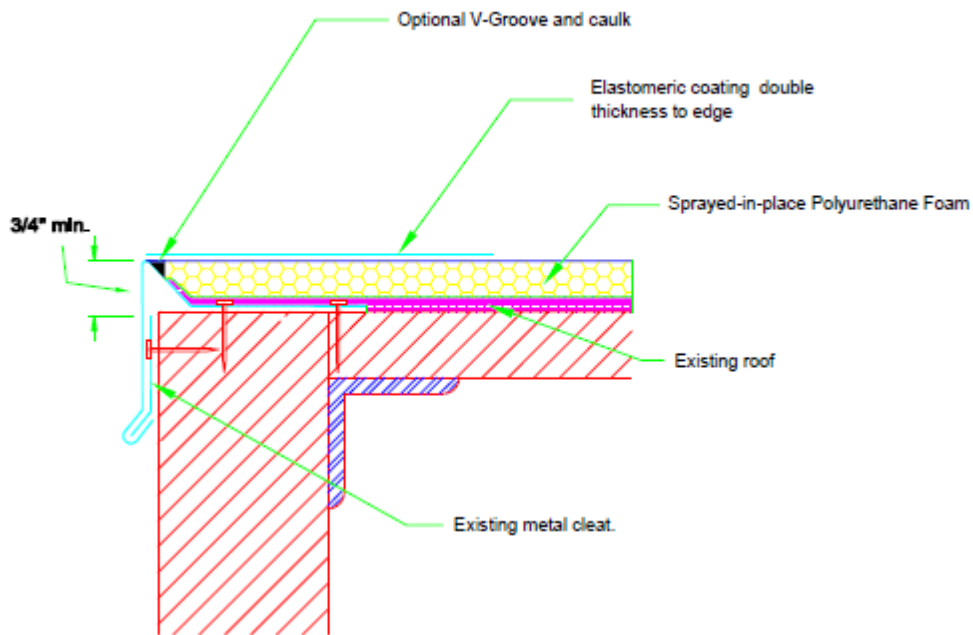

NOTES:

Spud clean existing BUR at edge 3/4" min. gravel stop.
Prime exposed gravel stop and secure as needed.

DETAIL DRAWING 3: TYPICAL ROOF EDGE WITH GUTTER

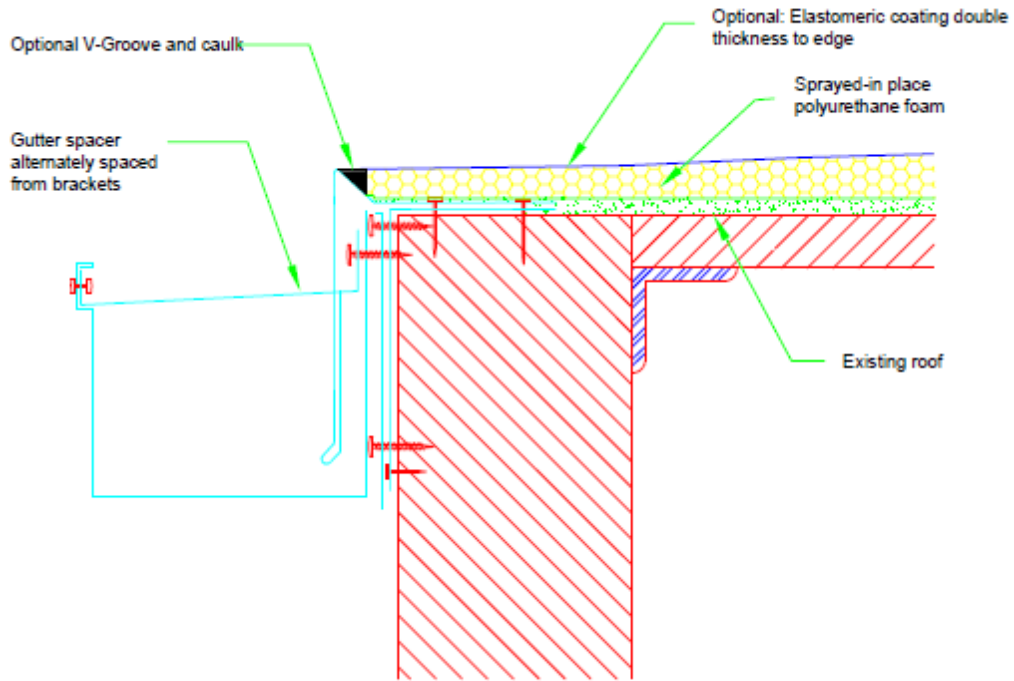

DETAIL DRAWING 4: NEW METAL PARAPET CAP

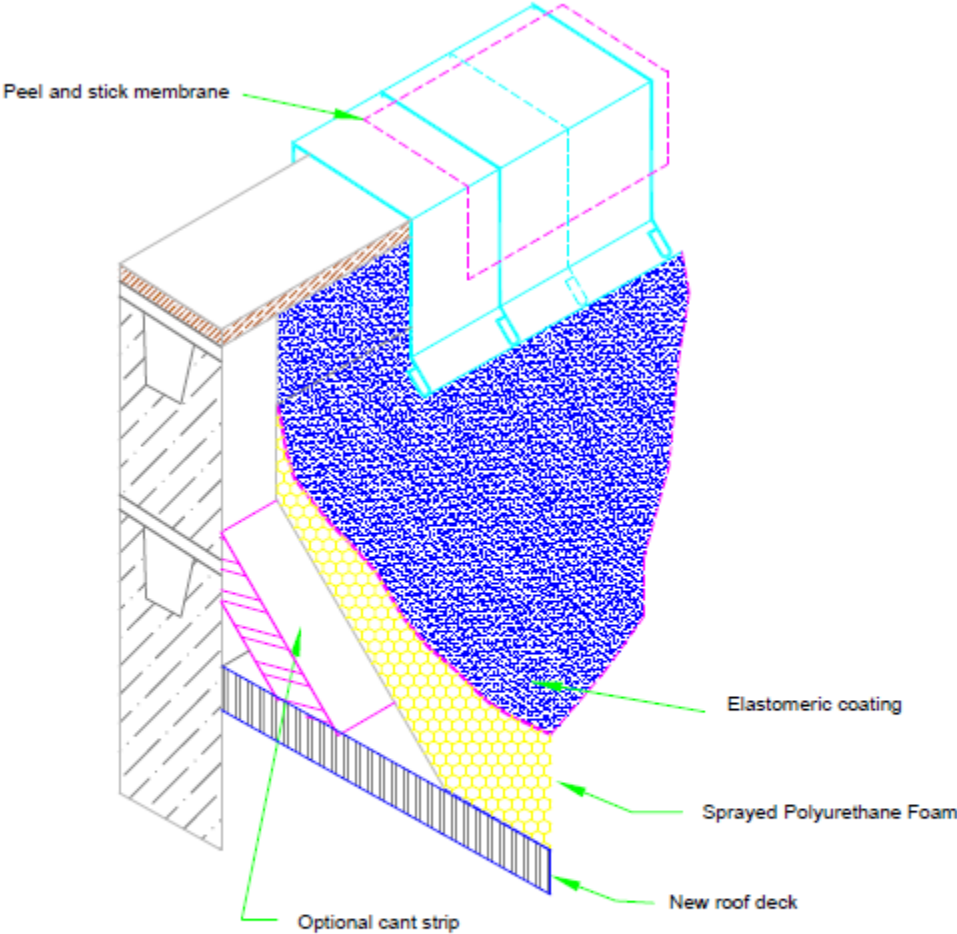

NOTES:

Free height shall be 8" above surface.
This detail should be used only when the deck is supported by the wall.

DETAIL DRAWING 5: EXISITING PARAPET WITH COPING

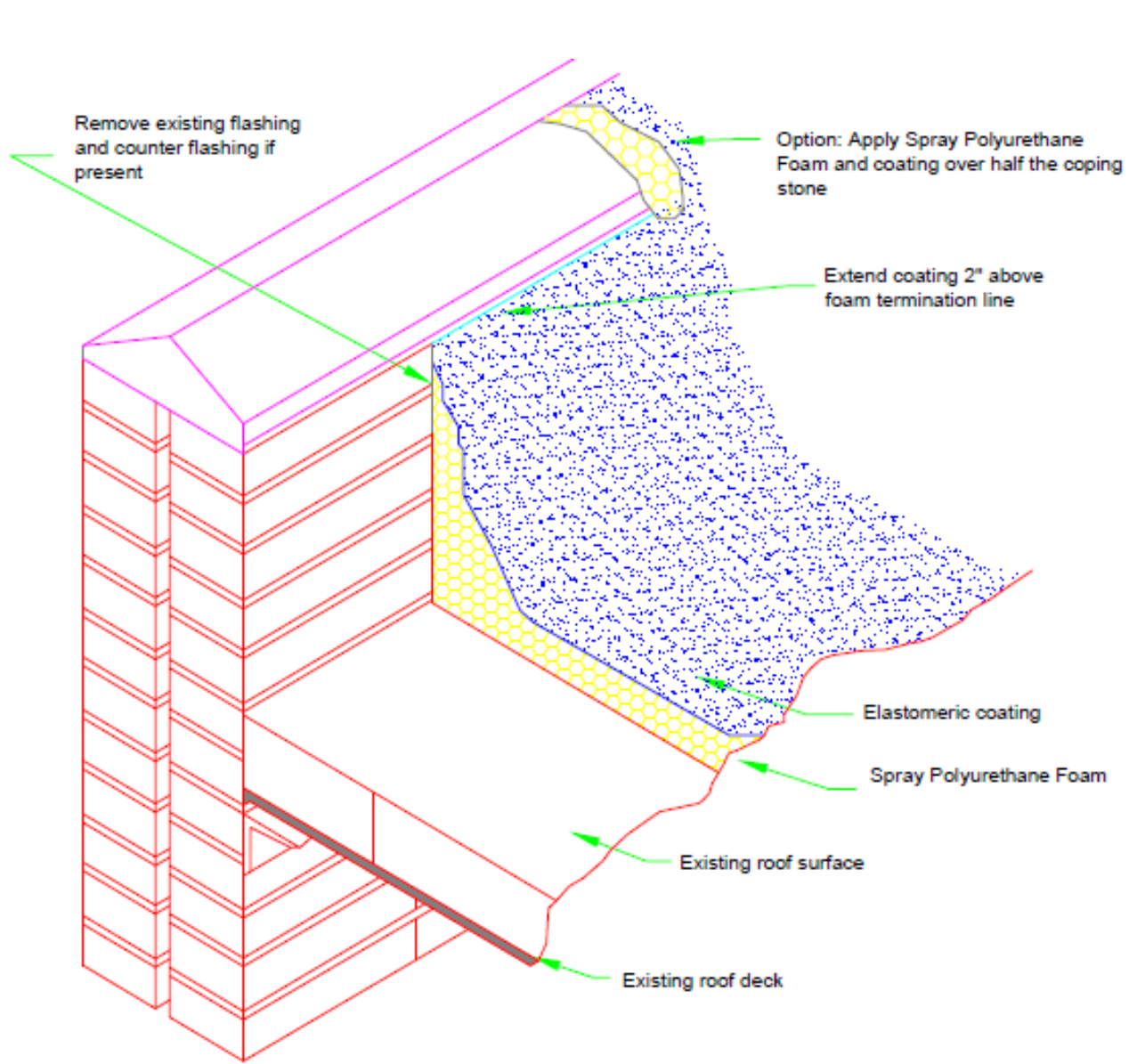

DETAIL DRAWING 6: NEW FLASHING FOR WALL SUPPORTED DECK

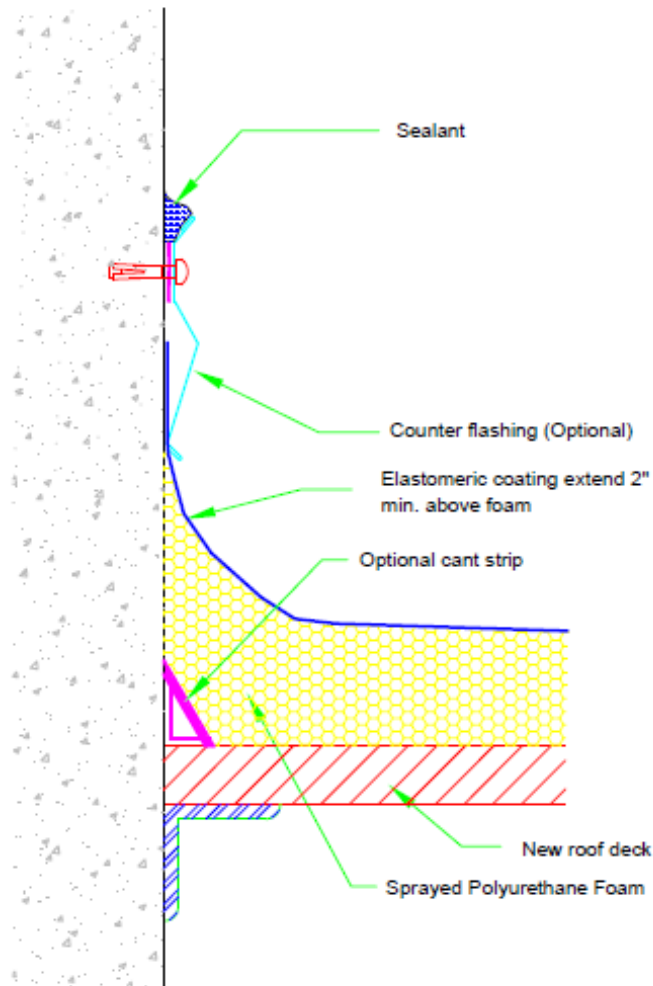

NOTES:

This detail to be used only when the deck is supported by the wall.

DETAIL DRAWING 7: HIGH WALL REMEDIAL THROUGH WALL FLASHING

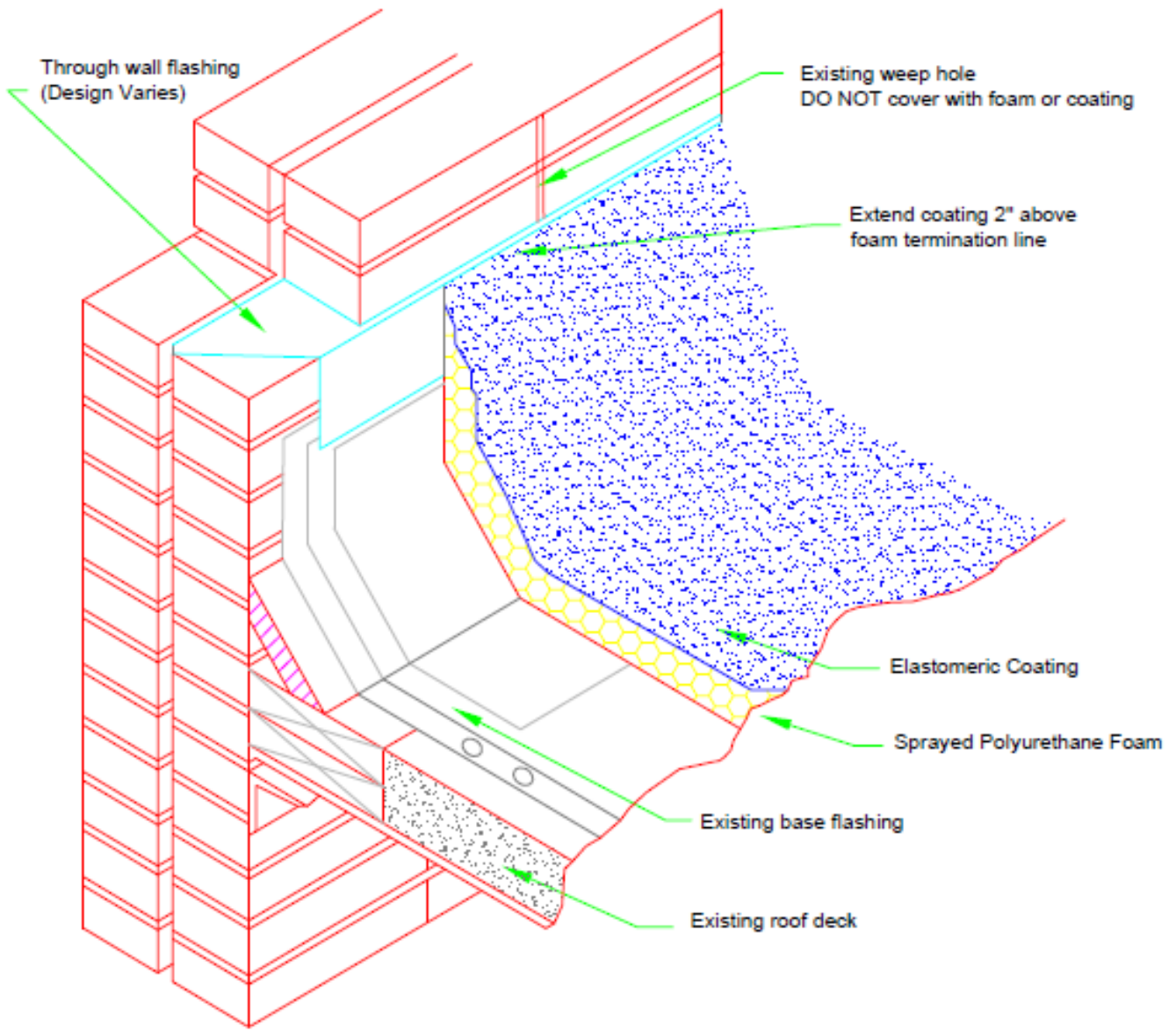

DETAIL DRAWING 8: FLASHING FOR NEW NON-WALL SUPPORTED DECK

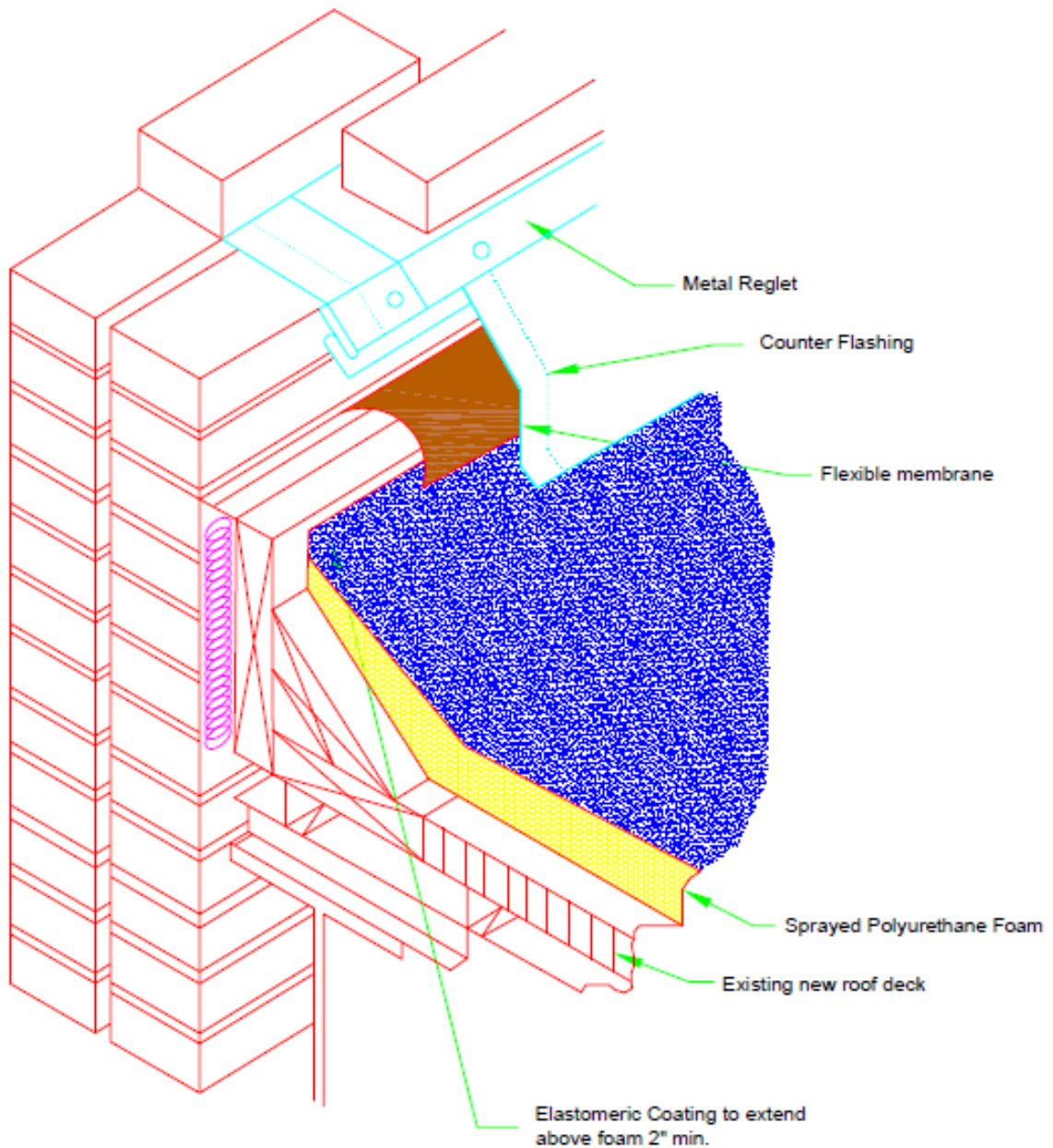

NOTES:

Free height should be 8"
above roof surface.

DETAIL DRAWING 9: NEW OR REMEDIAL SIDING OR HIGH WALL

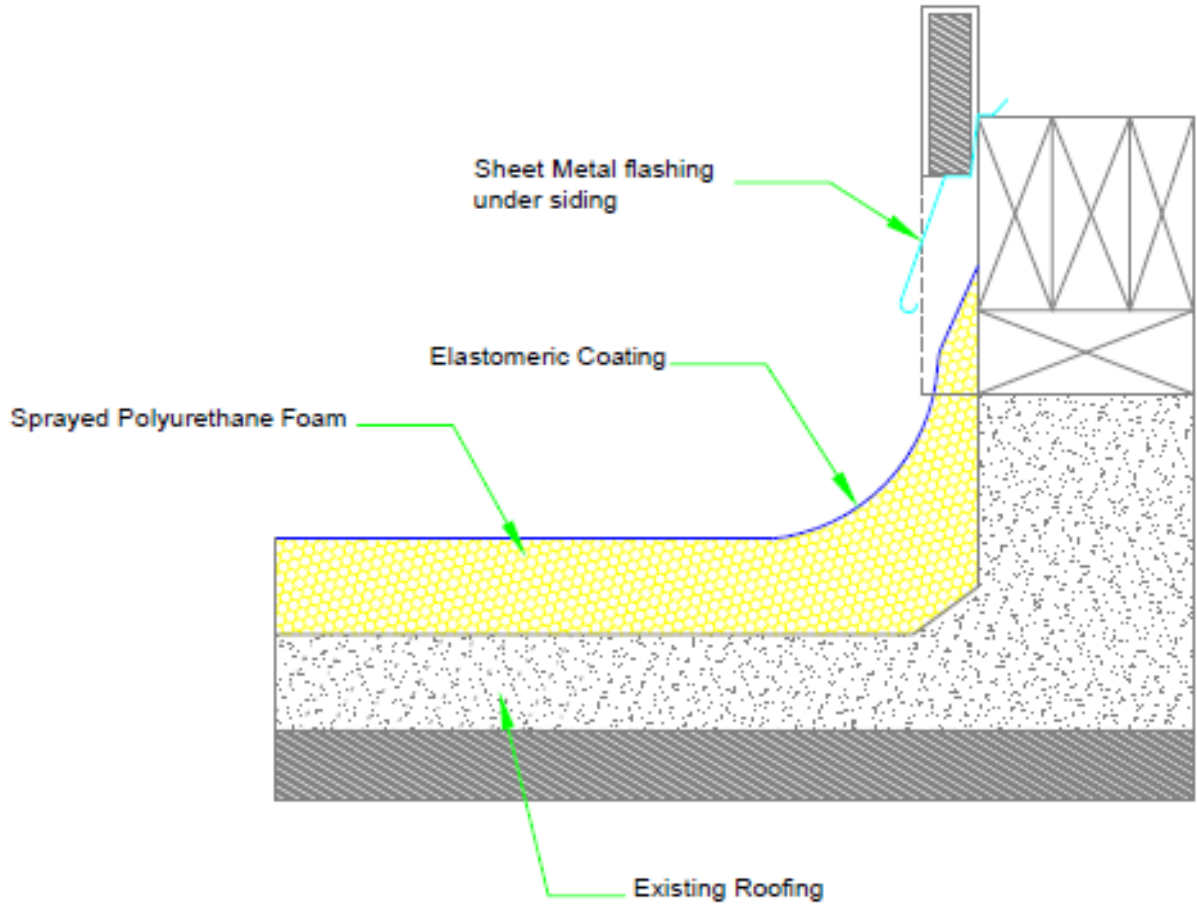

DETAIL DRAWING 10: TYPICAL EXISTING AREA DIVIDER

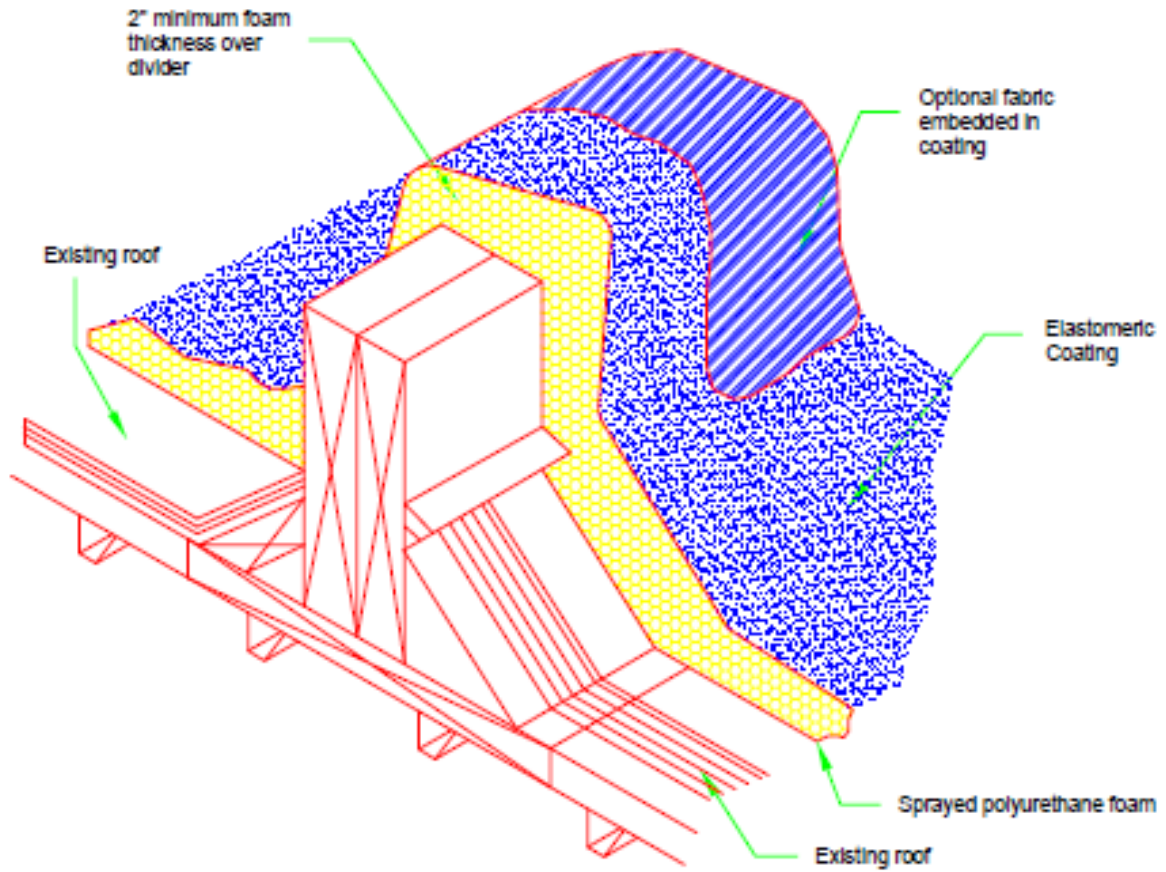

NOTES:

This can be used to separate one roof section from another or different types of roof systems

DETAIL DRAWING 11: REMEDIAL AREA DIVIDER

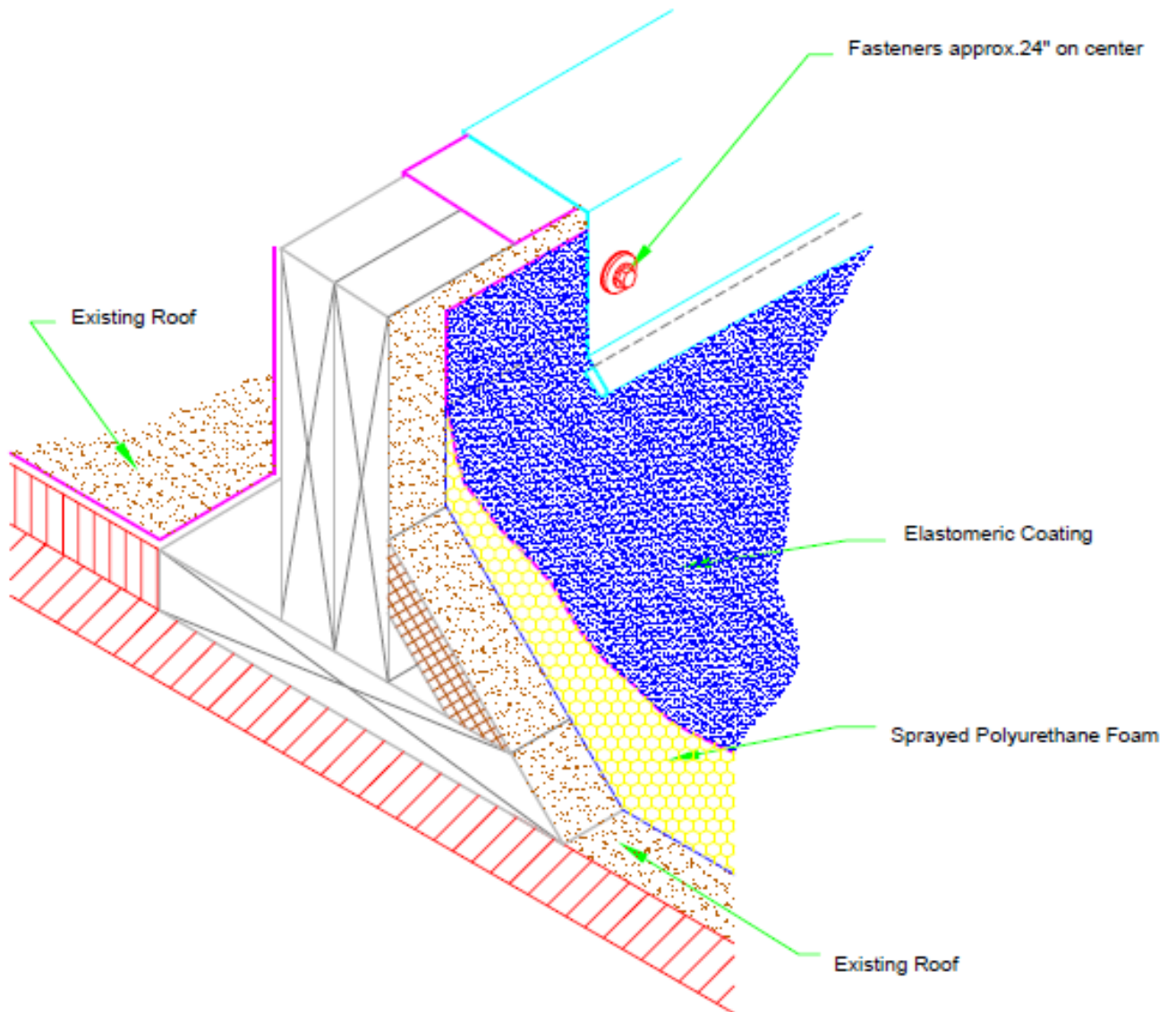

NOTES:

This area divider is designed simply to separate the existing roof system from the new sprayed-in-place polyurethane foam roof.

DETAIL DRAWING 12: TYPICAL ROOF DRAIN

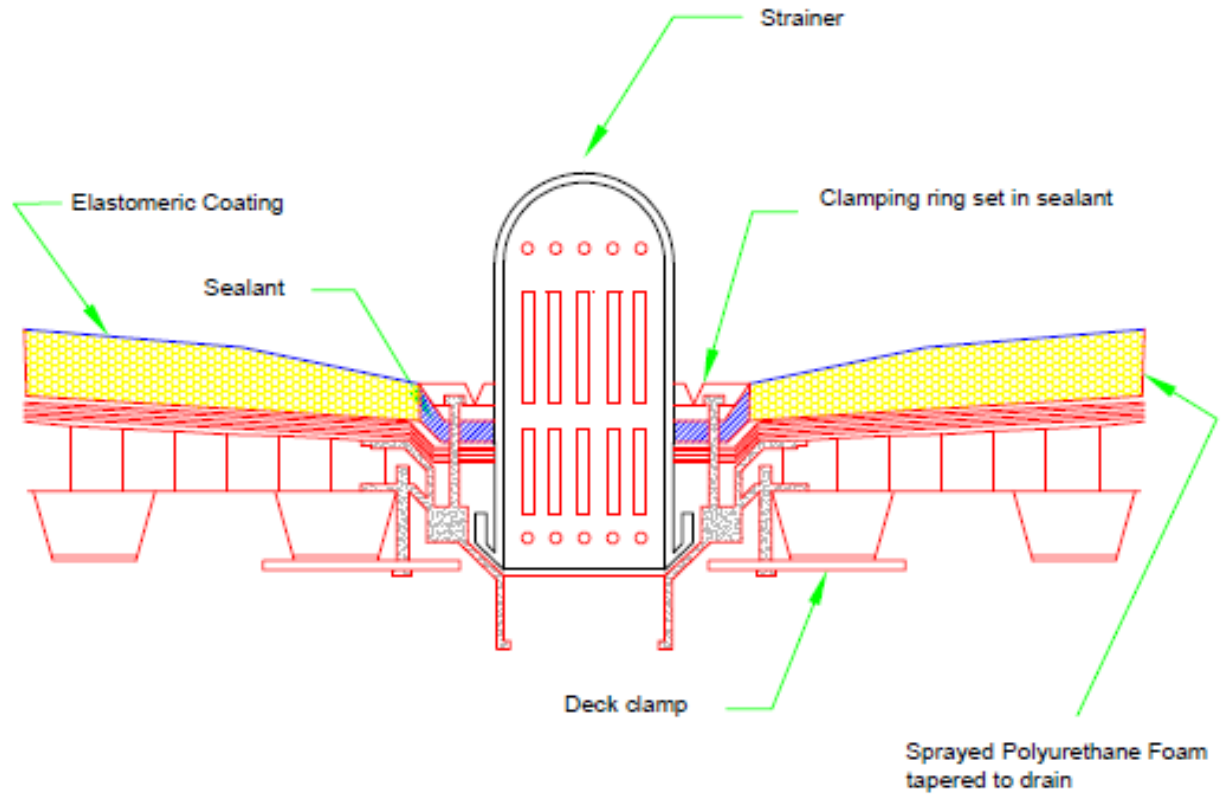

NOTES:

Mask clamping ring prior to spray foam application V-cut format clamping ring and apply sealant

DETAIL DRAWING 13: NEW OR REMEDIAL ROOF DRAIN

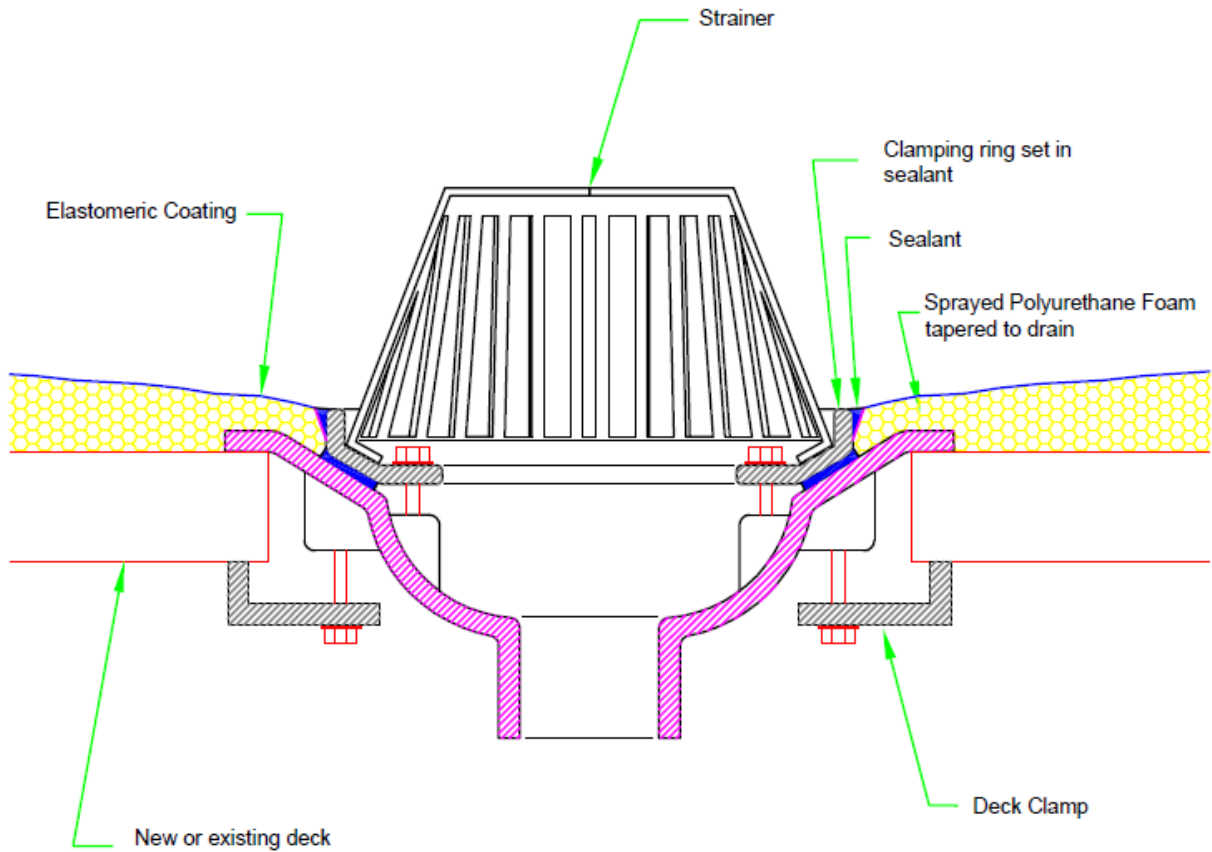

NOTES:

Prior to seating clamping ring, set in sealant, extend coating down into bowl.

DETAIL DRAWING 14: REMEDIAL DRAIN INSERT

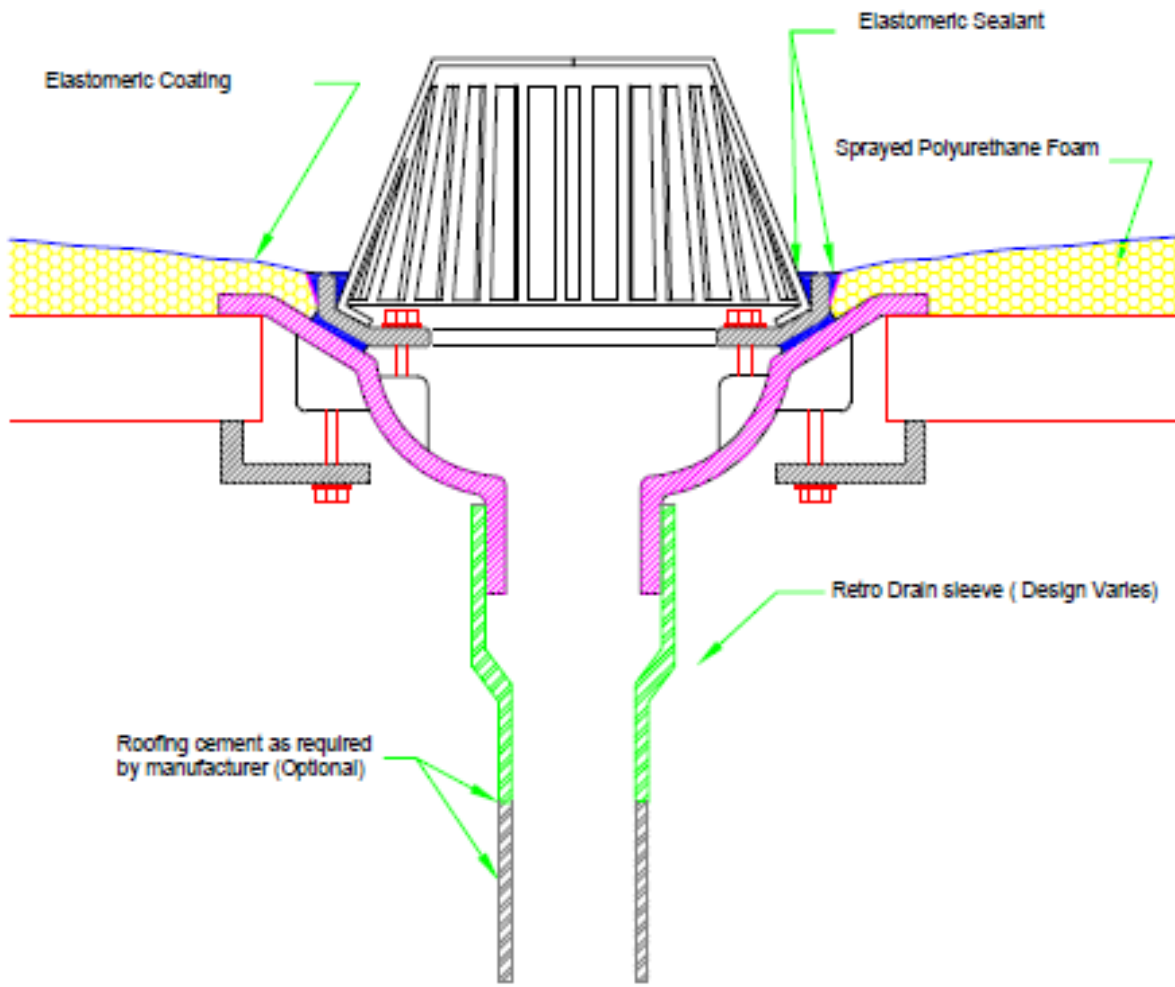

DETAIL DRAWING 15: NEW EXPANSION JOINT

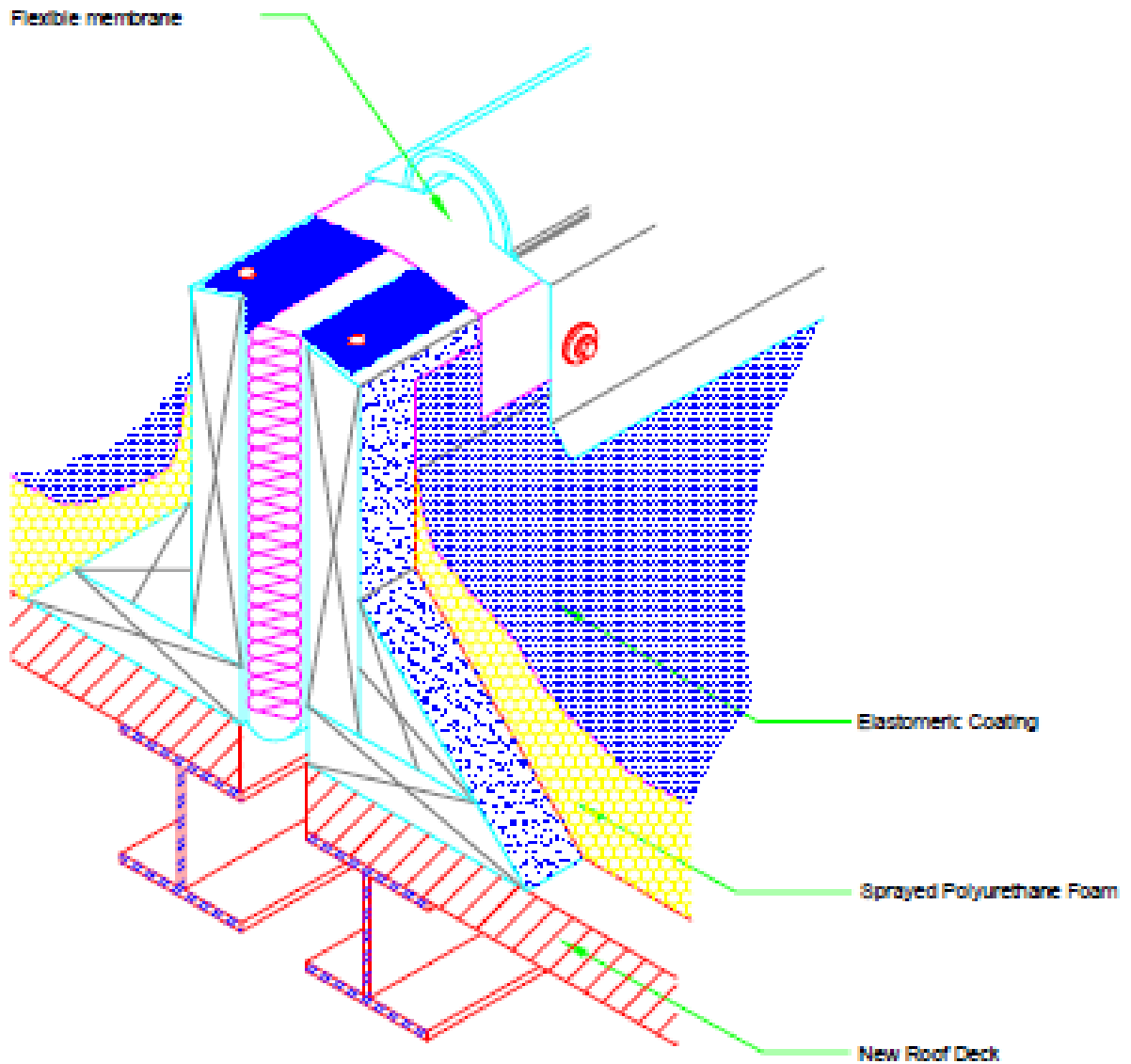

NOTES:

Free height shall be 8" above roof surface.

DETAIL DRAWING 16: REMEDIAL EXPANSION JOINT

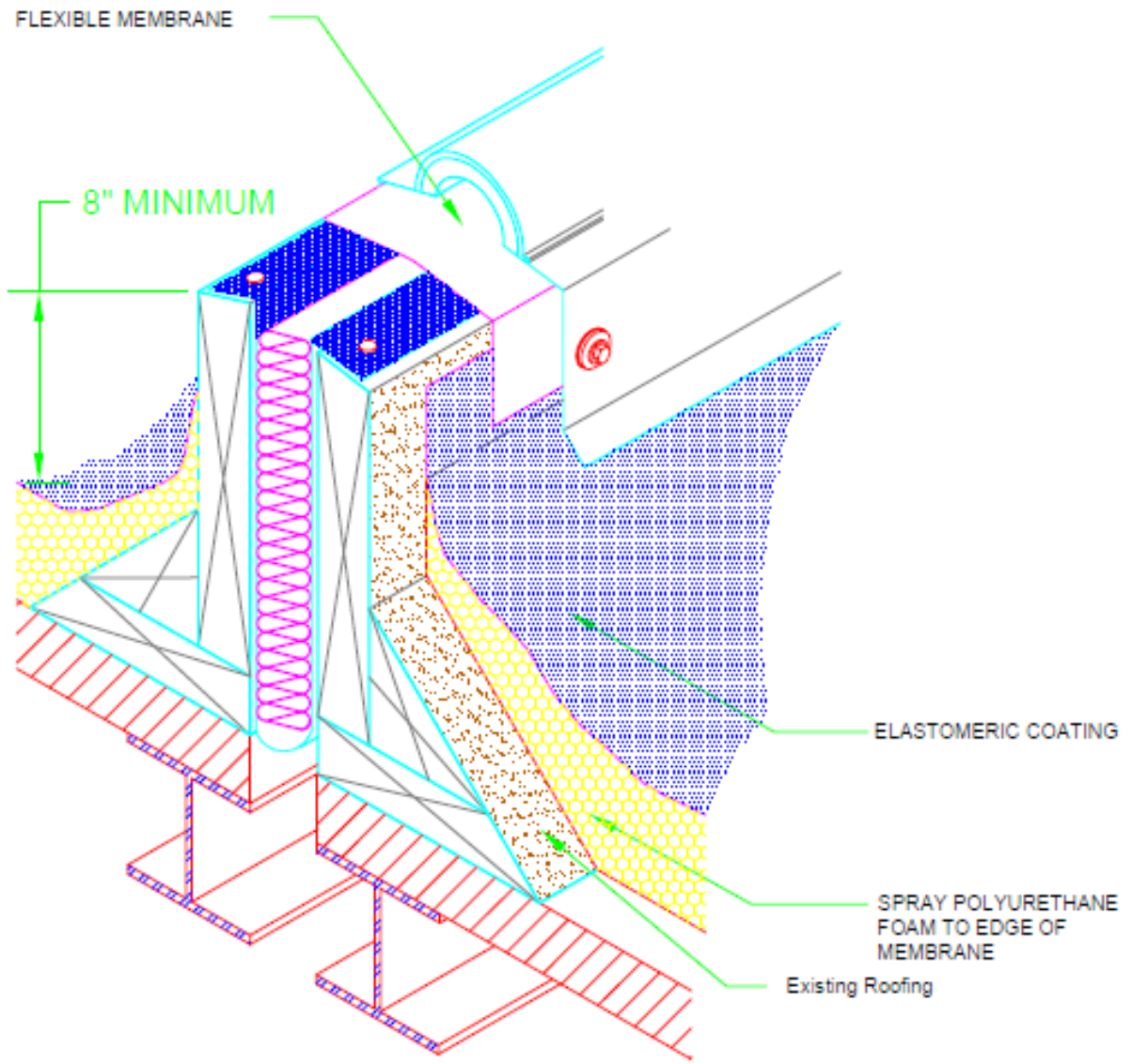

DETAIL DRAWING 17: SKYLIGHT, HATCH OR SMOKE VENT CURB

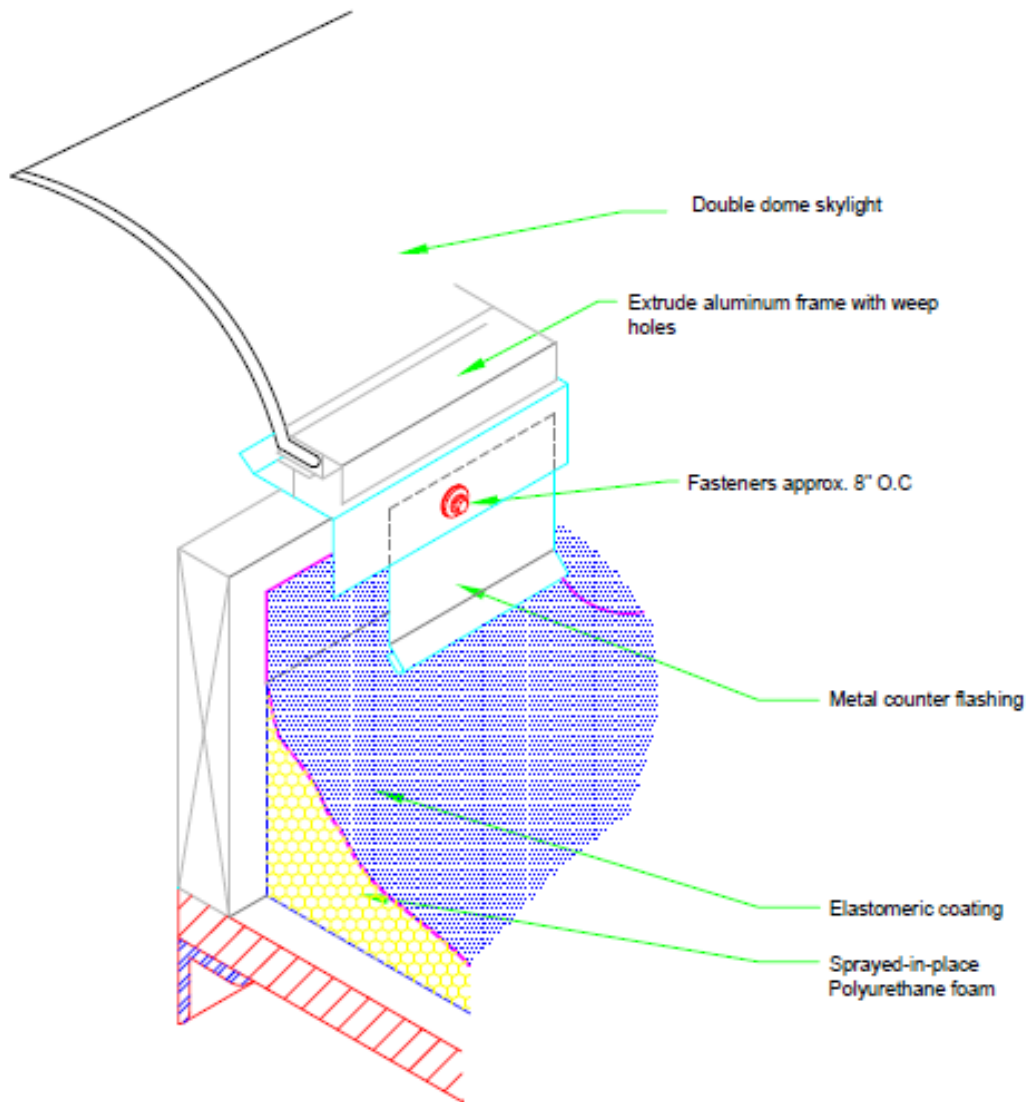

NOTES:

On Skylights, do not cover weep holes with polyurethane foam or coating

DETAIL DRAWING 18: NEW OR REMEDIAL HOT STACK FLASHING

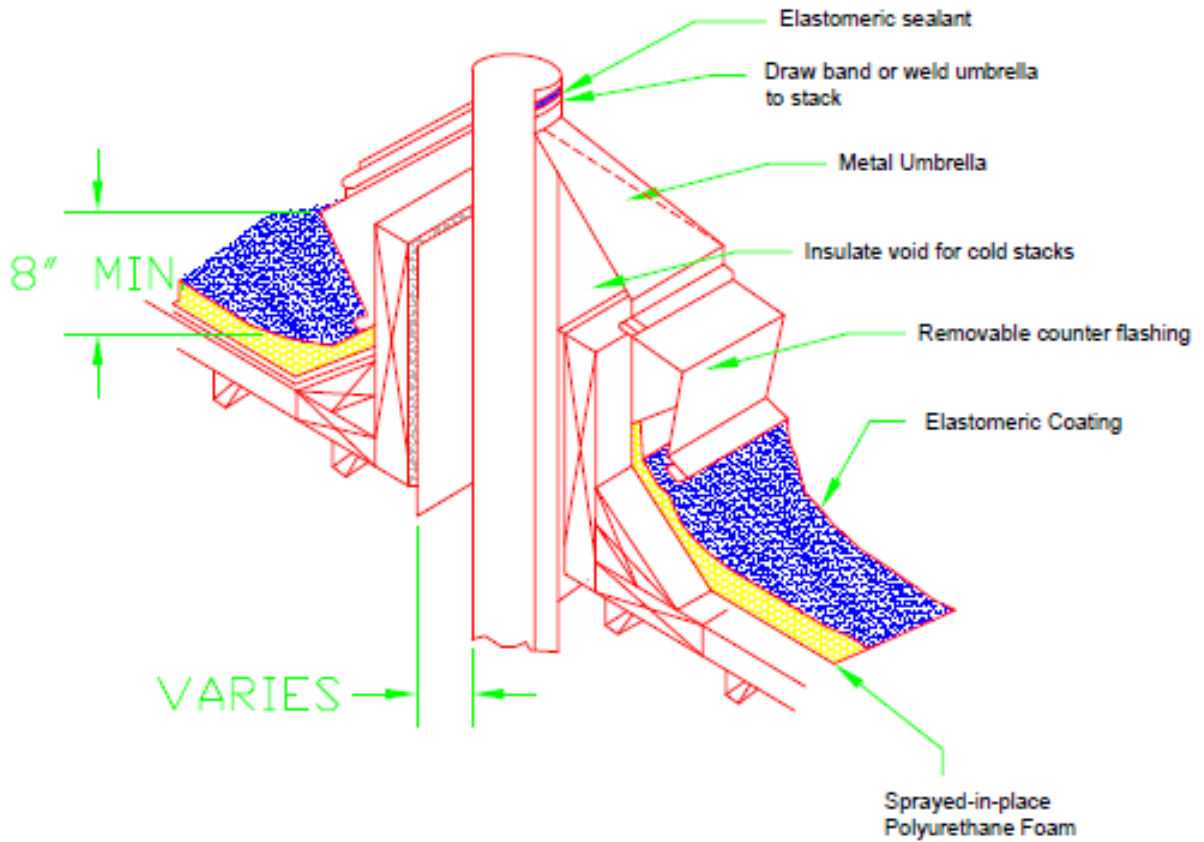

NOTES:

The metal sleeve and the clearance necessary will depend on the temperature of the material handled by the stack

DETAIL DRAWING 19: FLAT ROOF TO SHINGLE TIE IN

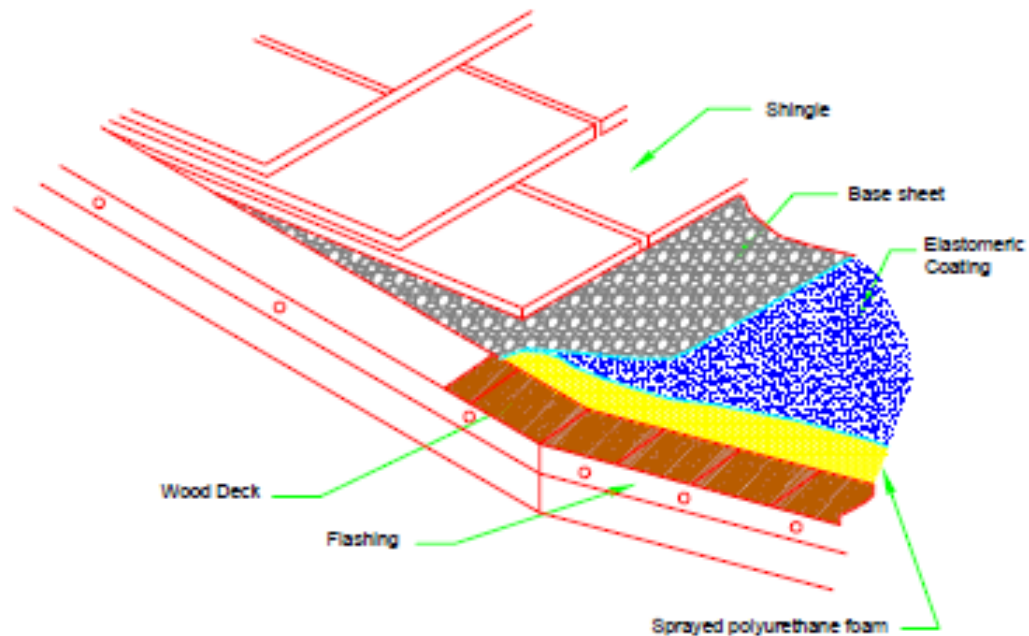

NOTES:

Base sheet should be aluminum flashing and the coating should extend under the bottom layer of the shingle.
Sprayed polyurethane foam must be applied beneath the base sheet.

DETAIL DRAWING 20: NEW AND REMEDIAL FLUTED METAL DECK

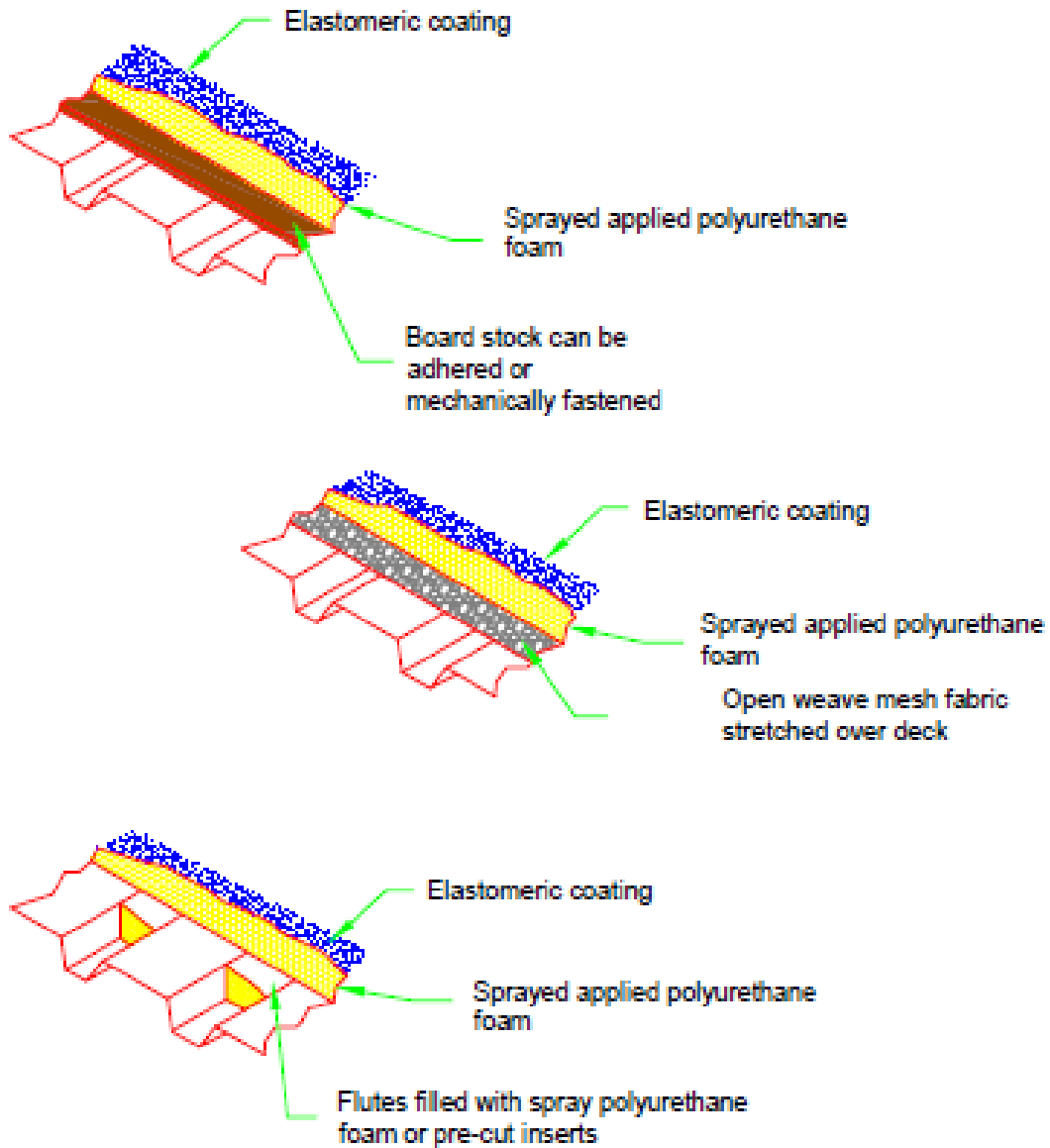

DETAIL DRAWING 21: WATER STOP

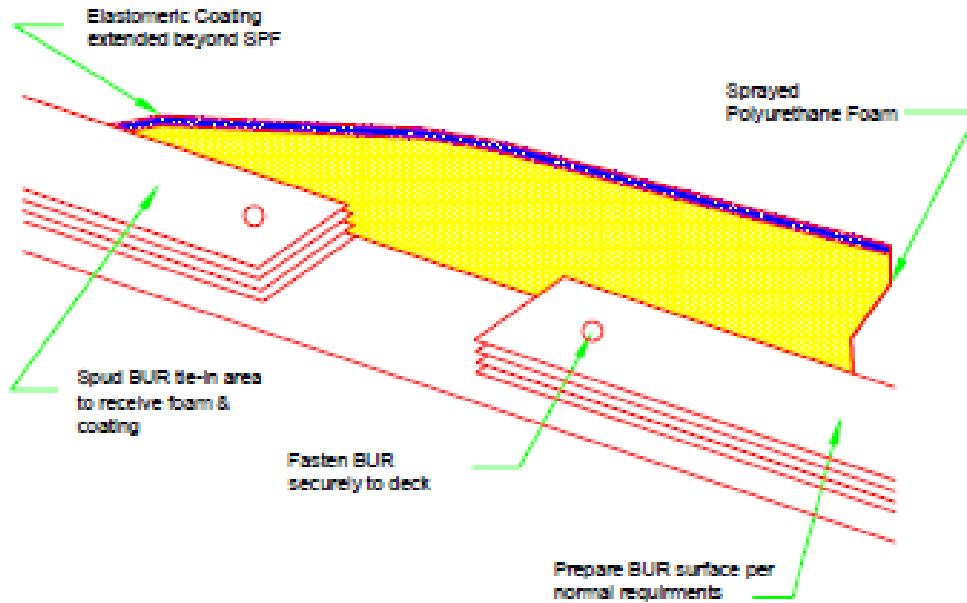

NOTES:

This detail to be used when terminating SPF roof onto a BUR roof

DETAIL DRAWING 22: REMEDIAL PROTRUSION FLASHING

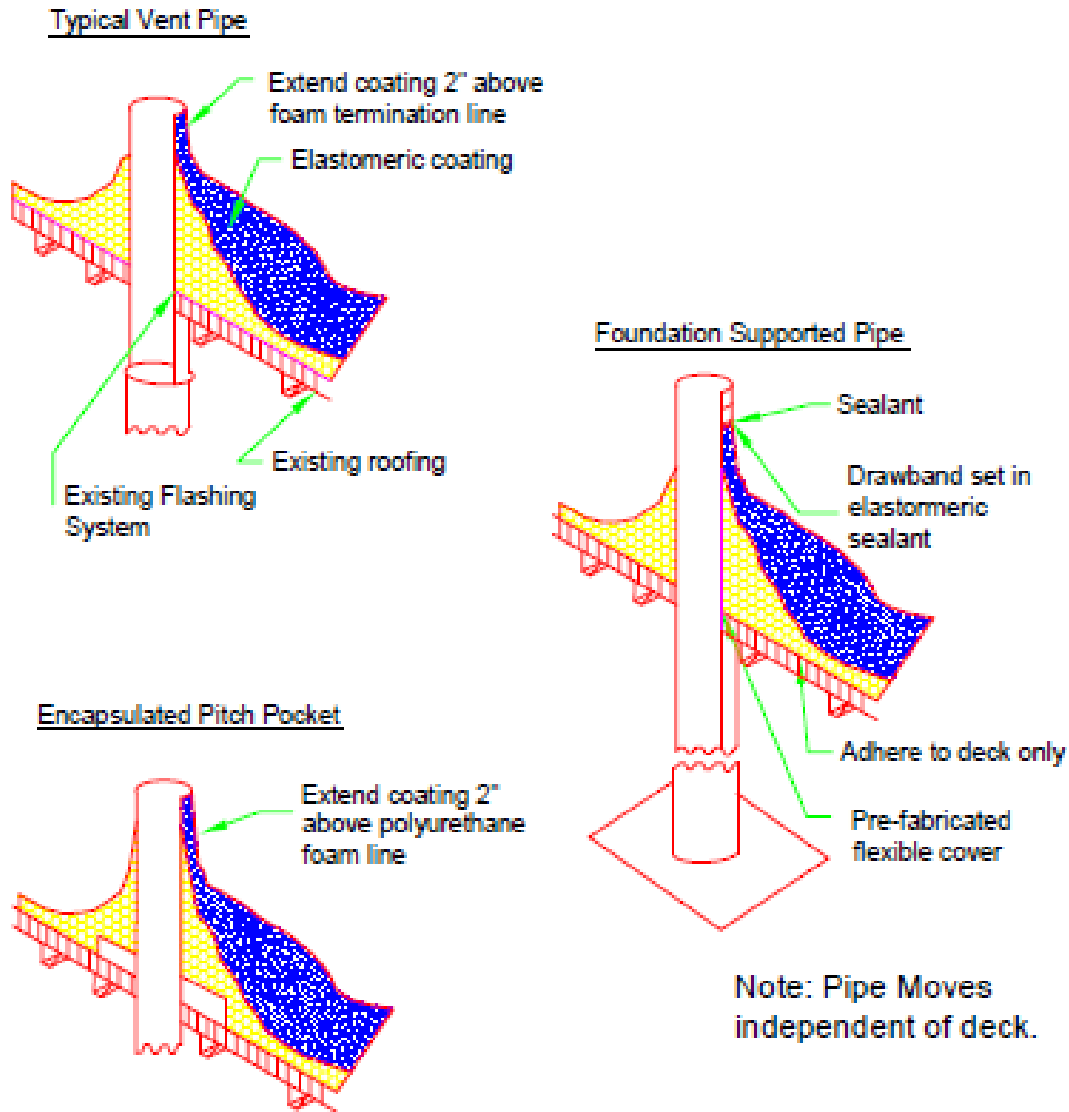

DETAIL DRAWING 23: RAISED CURB DETAIL (PREFABRICATED METAL CURB)

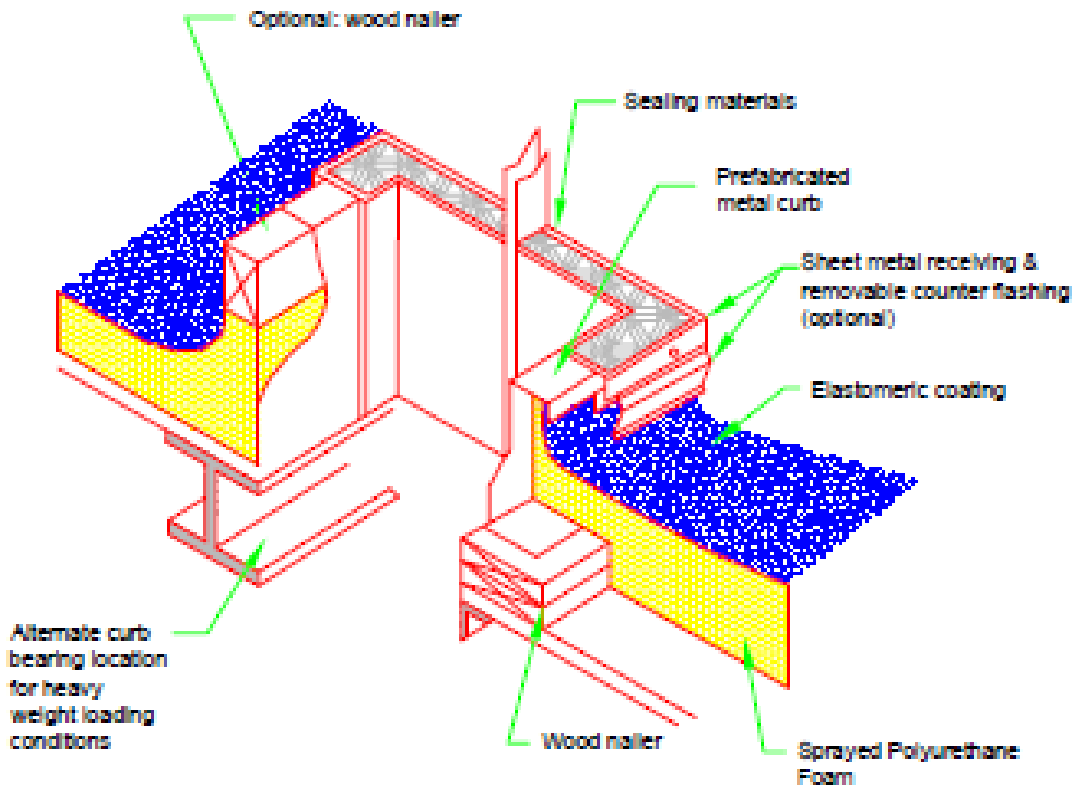

DETAIL DRAWING 24: RAISED CURB DETAIL (JOB SITE CONSTRUCTION WOOD CURB)

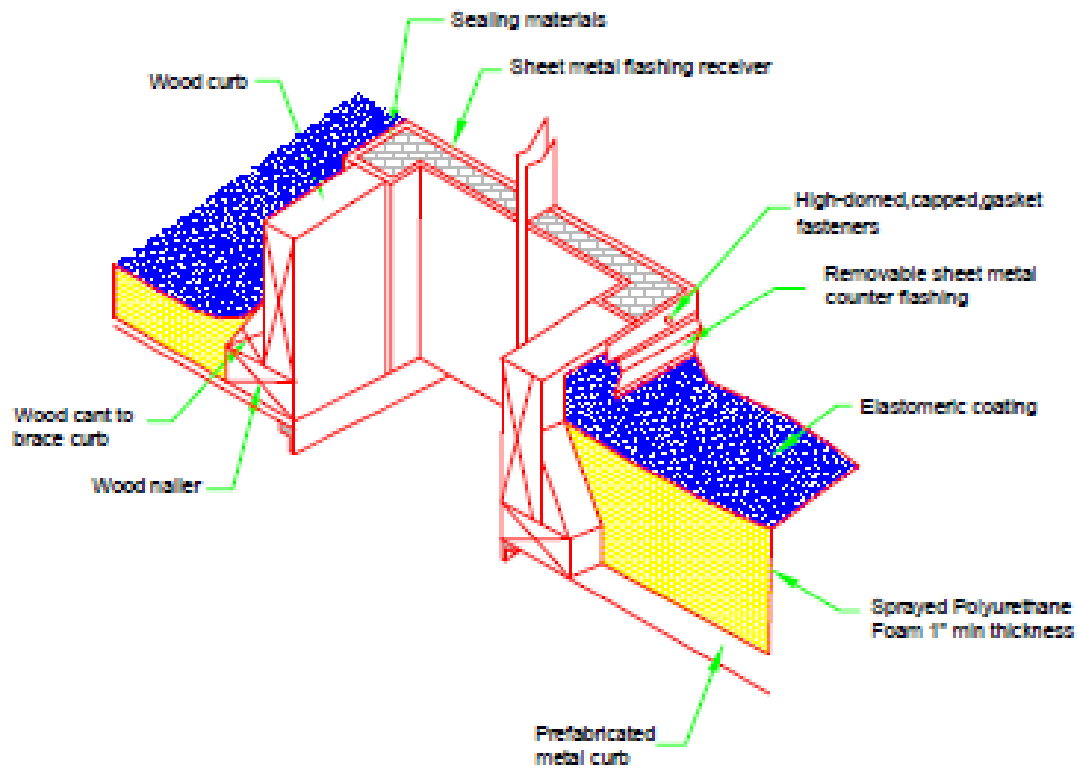

DETAIL DRAWING 25: REMEDIAL AIR CONDITIONER TREATMENT

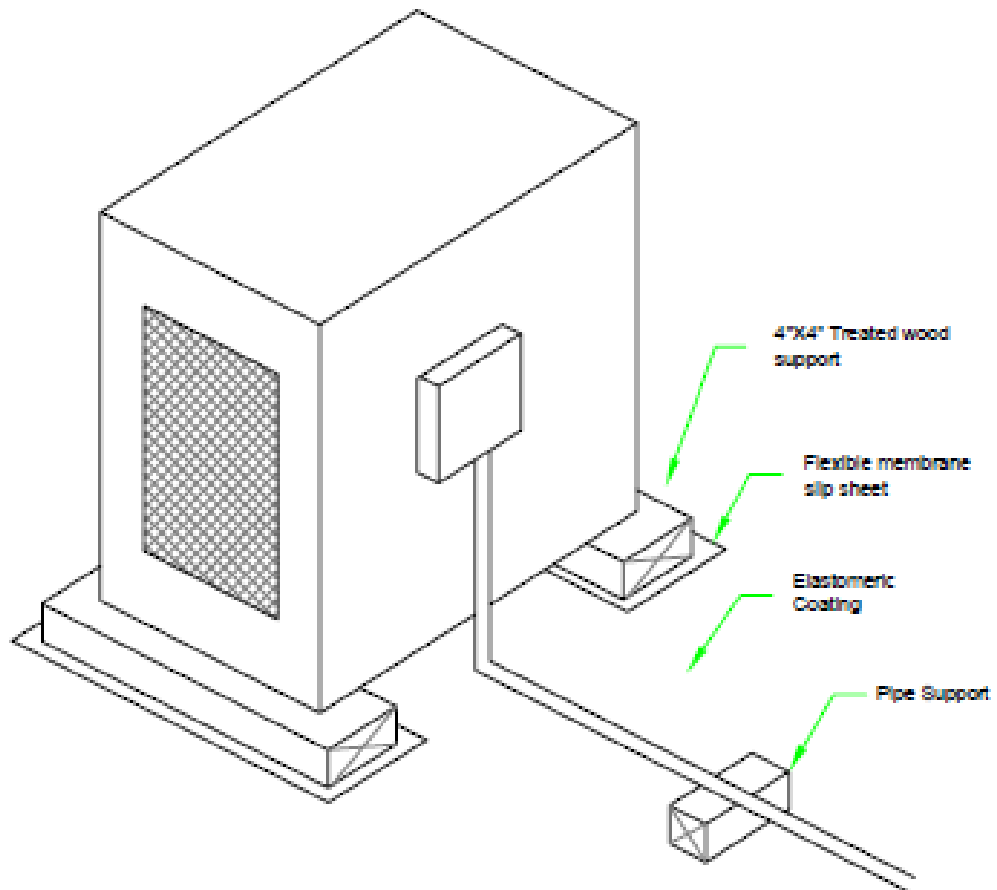

NOTES:

Pipe condensate to drain.

APPENDIX B: Surface Texture of Spray Polyurethane Foam

SPF (spray polyurethane foam) surface texture is the resulting surface from the final pass of SPF. The following terms are used to describe the types of SPF surfaces: smooth, orange peel, coarse orange peel, verge of popcorn, popcorn, and tree bark.

In SPF roofing applications, the texture of the sprayed foam is important in the performance of the roofing system. The rougher the texture, the more coating is required to provide the minimum dry-film thickness specified. When the surface becomes too rough or uneven, it is difficult to successfully provide the minimum specified coating thickness to all surface areas of the foam.

SURFACE TEXTURE OR FINISH

- (4) The SPF surface must be free of moisture, frost, dust, debris, oils, tars, grease, or other materials that will impair adhesion of the protective coating.
- (5) Any damage or defects to the SPF surface must be repaired prior to the application of the protective covering.
- (6) The final SPF surface texture will fall under one of the following labels:

- 1. Smooth
- 2. Orange peel
- 3. Coarse orange peel
- 4. Verge of popcorn
- 5. Popcorn
- 6. Tree bark

- (7) Textures numbered 1–3 are acceptable for the application of a protective coating. Number 4, verge of popcorn, is acceptable if properly coated. Textures numbered 1–4 are acceptable for aggregate covered surfaces. Numbers 5–6 are not acceptable. They must be removed and re-foamed to an acceptable surface.

Acceptable (1, 2, 3)	If Properly Coated (4)	Unacceptable (5 and 6)
----------------------	------------------------	------------------------

See the following pages for photos and a complete description of the surface textures. The 1 cm scale shown in each image is approximate.

SMOOTH SURFACE TEXTURE (1)

Description: The surface shows spray undulation and is ideal for receiving a protective coating.

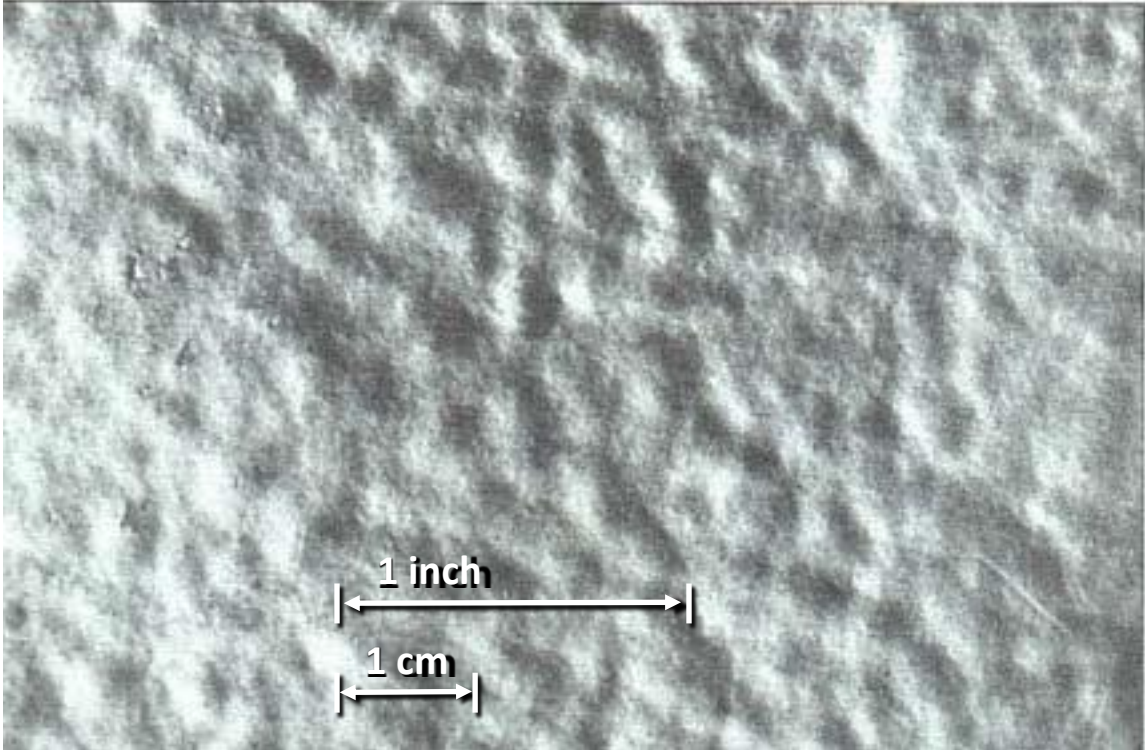

ORANGE PEEL SURFACE TEXTURE (2)

Description: The surface shows a fine texture and is compared to the exterior skin of an orange. This surface is considered acceptable for receiving a protective coating.



COARSE ORANGE PEEL SURFACE TEXTURE (3)

Description: The surface shows a texture where nodules and valleys are approximately the same size and shape. This surface is acceptable for receiving a protective coating because of the roundness of the nodules and valleys.

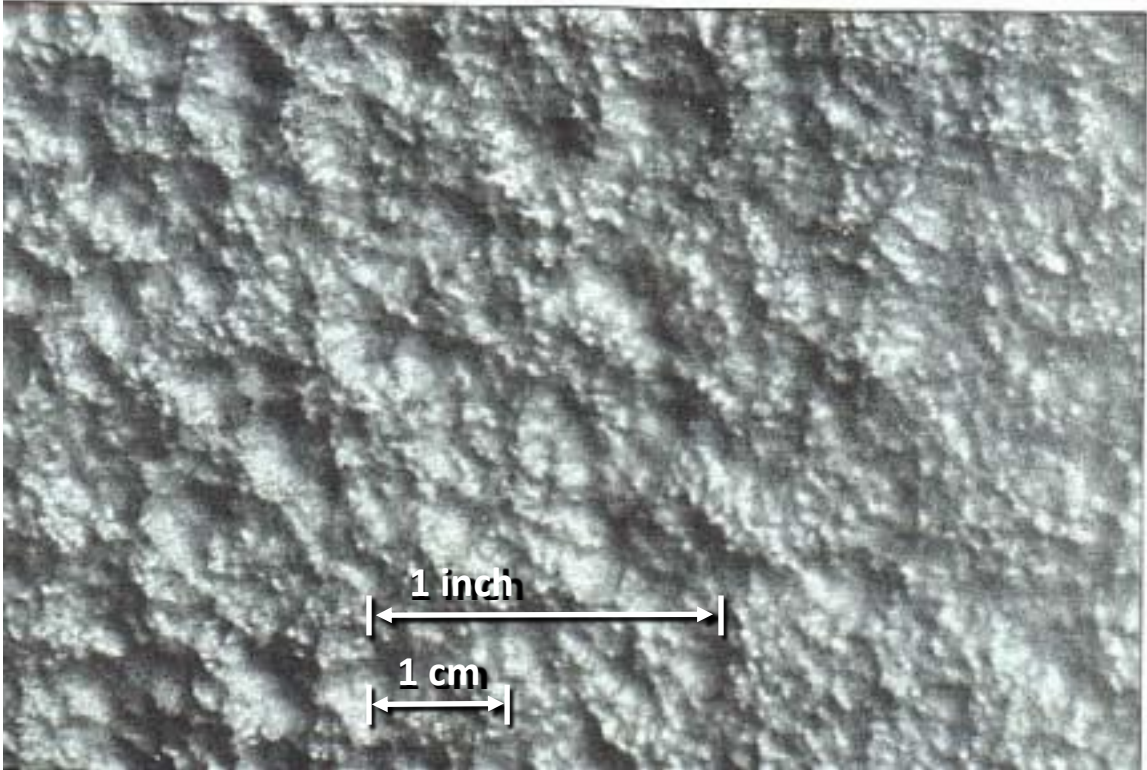

VERGE OF POPCORN TEXTURE (4)

Description: The verge of popcorn surface texture is the roughest texture suitable for receiving the protective coating. The surface shows a texture where nodules are larger than valleys, with the valleys relatively curved. This surface is acceptable for receiving a protective coating only because of the relatively curved valleys. However, the surface is considered undesirable because of the additional amount of coating material required to protect the surface properly.

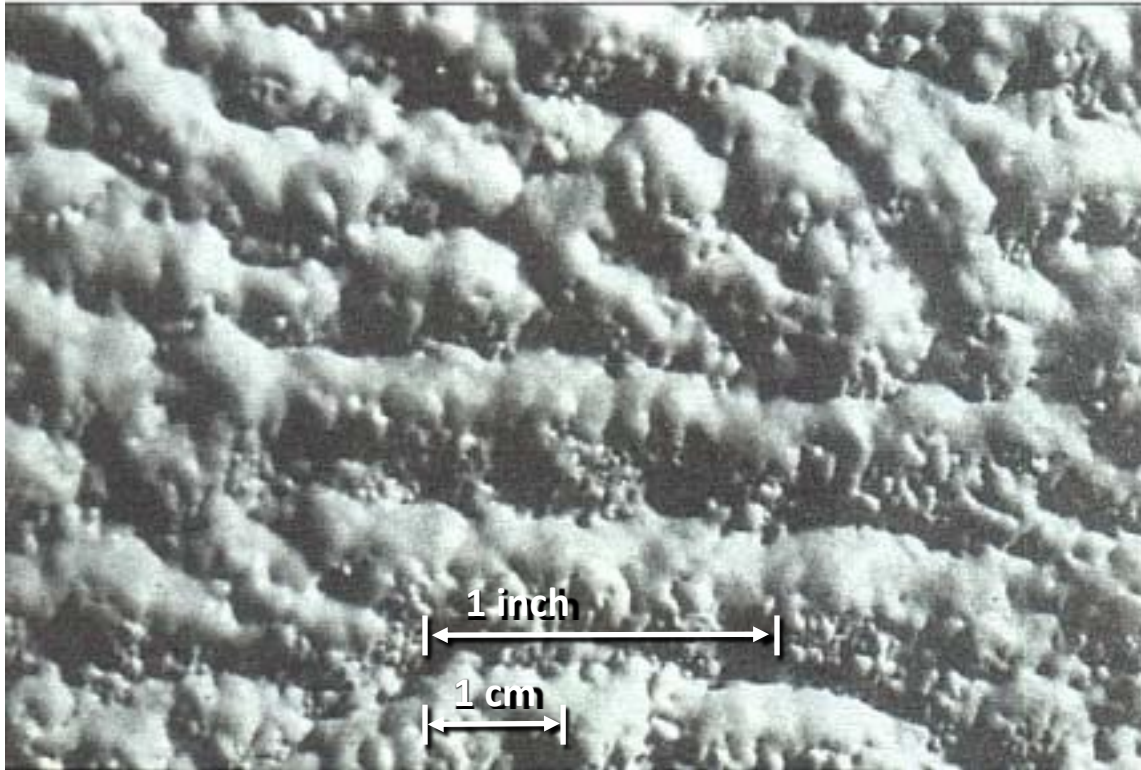

POPCORN SURFACE TEXTURE (5)

Description: The surface shows a coarse texture where valleys form sharp angles. This surface is unacceptable for proper coating and protection.

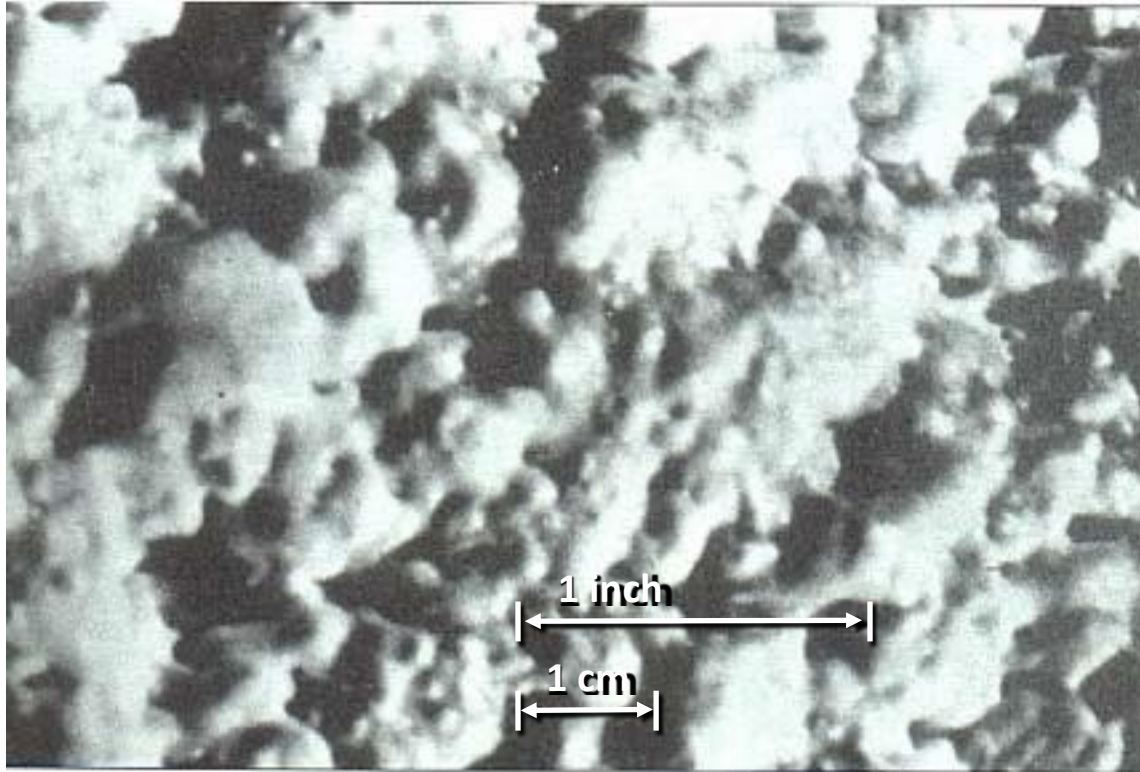

TREEBARK SURFACE TEXTURE (6)

Description: The surface shows a coarse texture where valleys form sharp angles. This surface is unacceptable for proper coating and protection.

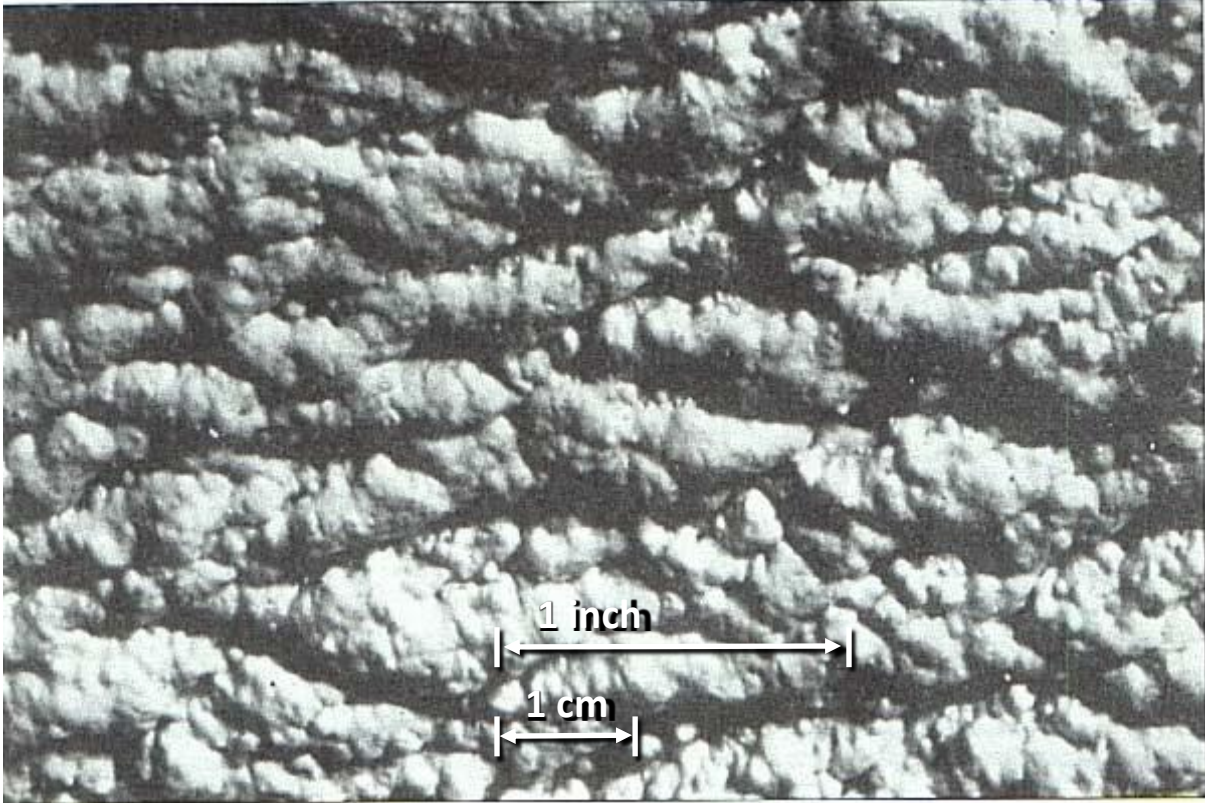

OTHER PROGRAMS AND SERVICES OFFERED BY SPFA

PROFESSIONAL TRAINING

The SPFA Professional Program offers individual certification and company accreditation in five areas: Contractor, Distributor, Elastomeric Coating Supplier, Foam Supplier, and Independent Inspector. The objectives of the program are to **PROVIDE** an established set of criteria, to **IDENTIFY** and **RECOGNIZE** individuals and companies, and to **ENCOURAGE** individual and company responsibility for the quality of work through self-education.

TECHNICAL DOCUMENTS

SPFA-102	A Guide for Selection of Protective Coatings over Spray Polyurethane Foam Roofing Systems
SPFA-103	Spray Polyurethane Foam Insulation Systems for Metal Service Vessels Operating Between -30°F and 200°F
SPFA-104	Spray Polyurethane Foam Systems for New and Remedial Roofing
SPFA-107	Spray Polyurethane Foam Blisters – Their Causes, Types, Prevention and Repair
SPFA-110	Spray Polyurethane Foam Aggregate Systems for New and Remedial Roofing
SPFA-111	Spray Polyurethane Foam Systems for Cold Storage Facilities Operating Between -40°F and 50°F
SPFA-112	Spray Polyurethane Foam for Building Envelope Insulation and Air Seal
SPFA-113	Contractor/Applicator Handbook
SPFA-116	Spray-Applied Polyurethane Foam and Elastomeric Coating Systems (10 min. VHS Video)
SPFA-117	Spray-Applied Polyurethane Foam and Aggregate Roof Systems (10 min. VHS Video)
SPFA-118	Moisture Vapor Transmission
SPFA-119	Glossary of Terms Common to the Spray Polyurethane Foam Industry
SPFA-121	Spray Polyurethane Foam Estimating Reference Guide
SPFA-122	The Renewal of Spray Polyurethane Foam and Coating Roof Systems
SPFA-124	Wind Uplift Brochure
SPFA-125	P-Rating Brochure
SPFA-126	Thermal Barriers for the Spray Polyurethane Foam Industry
SPFA-127	Maintenance Manual for Spray Polyurethane Foam Roof Systems
SPFA-129	SPF Roofing “Seamless Roofing and Insulation” (8-page Color Brochure)
SPFA-130	SPF Roofing “Sustainable Roofing” (4-page Color Brochure)
SPFA-131	Whole Wall Rating/Label for Metal Stud Wall Systems with SPF; Steady State Thermal Analysis
SPFA-132	The SPF Roofing Systems (11.5 min. informative video offering a comprehensive pictorial review of this most extraordinary roofing concept)
SPFA-133	Maintenance Manual for Spray Polyurethane Foam Roof Systems (Spanish Version)
SPFA-134	Guideline for Insulating Metal Buildings with Spray Polyurethane Foam
AX-171	Course 101-R Chapter 1: Health, Safety and Environmental Aspects of Spray Polyurethane Foam and Coverings (Video and Text)

- The **SPFA website** is a direct communication to all member suppliers and contractors with web access. Up-to-date information is offered, and, as a member, you may link into the website: www.sprayfoam.org.

- A **“Support Line” 800-number** is available for your use to answer technical questions (800-523-6154). The SPFA sponsors research and development and product testing that allows for approval of generic types of spray foams, coverings, and related products.